



**Taylor-Wharton**  
Since 1742

## **Instruction Manual**

**XL-45, XL-50, XL-55, XL-60, XL-65 and XL-70**



---

Do not attempt to use or maintain these units until you read and understand these instructions. Refer to the Taylor-Wharton's Safety First booklet (TW-202) for handling cryogenic material. Do not permit untrained persons to use or maintain this equipment. If you do not understand these instructions, contact your supplier for additional information.

---

Manual GL-SERIES  
T-W P/N# 7950-8092  
May 30, 2018

# TABLE OF CONTENTS

---

XL-45/50/55/60/65/70-----	0
CONTAINER SAFETY -----	2
GENERAL INFORMATION-----	3
SPECIFICATIONS -----	4
OPERATION-----	6
COMPONENT DESCRIPTION -----	6
PURGE PROCEDURE-----	9
WITHDRAWING GAS FROM THE CONTAINER-----	11
WITHDRAWING LIQUID FROM THE CONTAINER -----	11
FILLING THE CONTAINER -----	12
MAINTENANCE PROCEDURE-----	16
CONVERTING A CONTAINER TO DIFFERENT GAS SERVICE-----	16
REGULATOR MAINTENANCE -----	17
CHECKING CONTAINER PERFORMANCE -----	19
FULL VIEW CONTENTS GAUGE MAINTENANCE -----	20
HAND VALVE REPAIR -----	22
SHOCK MOUNT FOOTRING-----	23
TROUBLESHOOTING -----	25
REPLACEMENT PARTS-----	27
ACCESSORIES-----	27

## CONTAINER SAFETY

### **WARNING**

**Following safety precautions are for your protection. Before performing installation, operating, or maintenance procedures read and follow all safety precautions in this section and in reference publications. Failure to observe all safety precautions can result in property damage, personal injury, or possible death. It is the responsibility of the purchaser of this equipment to adequately warn the user of the precautions and safe practices for the use of this equipment and the cryogenic fluid stored in it.**

### **Pressure Hazard**

The containers covered by this literature may contain pressure up to 230 psig (16 bar/1586 kPa.) Sudden release of this pressure may cause personal injury by issuing cold gas or liquid, or by expelling parts during servicing. Do not attempt any repairs on these containers until all pressure is released, and the contents have been allowed to vaporize to ensure no pressure build-up can occur. Before performing installation, operation, or maintenance procedures, read and follow all safety precautions in this section and in reference publications. Failure to observe all safety precautions can result in property damage, personal injury, or possible death. It is the responsibility of the purchaser of this equipment to adequately warn the user of the precautions and safe practices for use of this equipment and cryogenic fluid being used.

### **Extreme Cold - Cover Eyes and Exposed Skin**

Accidental contact of liquid methane or cold issuing gas with the skin or eyes may cause a freezing injury similar to frostbite. Handle the liquid so that it won't splash or spill. Protect your eyes and cover the skin where the possibility of contact with the liquid, cold pipes and cold equipment, or the cold gas exists. Safety goggles or a face shield should be worn if liquid ejection or splashing may occur or cold gas may issue forcefully from equipment. Clean, insulated gloves that can be easily removed and long sleeves are recommended for arm protection. Cuffless trousers should be worn outside boots or over the shoes to shed spilled liquid. Cryogenic liquids are extremely cold and will be at temperature below -300°F (-184°C) under normal atmospheric pressure.

### **Keep Equipment Area Well Ventilated**

Although some of the gases used in these containers are non-toxic and non-flammable, they can cause asphyxiation in a confined area without adequate ventilation. Any atmosphere which does not contain enough oxygen for breathing can cause dizziness, unconsciousness or even death. These gases cannot be detected by the human senses and will be inhaled normally as if it were air. Ensure there is adequate ventilation where these gases are used and store liquid containers or only in a well-ventilated area.

**Replacement Parts Must be "Cleaned for Oxygen Service"** - Some materials, especially non-metallic gaskets and seals, can be a combustion hazard if used in oxygen or nitrous oxide service, although they may be acceptable for use with other cryogenic liquids. Use only Taylor-Wharton recommended spare parts, and be certain parts used on oxygen or nitrous oxide equipment are marked "clean for oxygen service." For information on cleaning, consult the Compressed Gas Association (CGA) pamphlet G-4.1, "Cleaning for Oxygen Service" or equivalent industrial cleaning specifications.

**CAUTION:** When installing field fabricated piping, make certain a suitable safety valve is installed in each section of piping between shut-off valves. Trapped liquefied gas will expand as it warms and may burst hoses or piping causing damage or personal injury.

For more detailed information concerning safety precautions and safe practices to be observed when handling cryogenic liquids consult CGA pamphlet P-12 'Handling Cryogenic Liquids' available from the Compressed Gas Association, 14501 George Carter Way, Suite 103, Chantilly VA 20151-2923, phone: 703-788-2700, fax: 703-961-1831.

---

## GENERAL INFORMATION

The XL-45, XL-50, XL-55, XL-60, XL-65 and XL-70 are vacuum-insulated, stainless steel containers design to store and transport cryogenic liquid oxygen, nitrogen and argon with continuous flow rates up to 350 cfh (9.2 cu.m/h) with a delivery pressure of approximately 100 psig (6.9 bar/690 kPa). The container is designed and constructed in according with DOT 4L standards, and may be used for over the road transportation of Ar, O<sub>2</sub>, & N<sub>2</sub> as well as on-site storage and supply in wide range of applications.

### Handling the Container

The XL Series containers are very rugged liquid cylinders. All Cryogenic liquid containers have an inner container and an outer container with an insulated vacuum space between them. Any abuse (dents, dropping, tip-over, etc.) can affect the integrity of the container's insulation system.

When fully loaded, the XL-45, XL-50, XL-55, XL-60, XL-65 and XL-70 in argon service will contain up to 471 lb. (214 kg), 506 lb. (235 kg), 540 lb. (245 kg), 628 lb. (286 kg), 659 lb. (299 kg) and 735 lb. (333 kg) of product, respectively. While moving a full container, you may be handling up to 715 lb. (325 kg), 761 lb. (350 kg), 802 lb. (364 kg), 1018 lb. (463 kg), 1027 lb. (466 kg) and 1111 lb. (504 kg), respectively and you should treat the load accordingly. The attachment points provided on the XL-45/50/55 will allow you to use a hand truck or a hoist to handle these loads properly. XL-60, XL-65 and XL-70 will allow you to use caster wheel for movement. Do not attempt to move these cylinders by any other means. While moving the cylinder, the following precautions should be observed:

- i. Never lay the container on its side. Always ship, operate, and store the unit in a vertical, or upright position.
- ii. When loading or unloading the container from a truck, use a hand truck, lift gate, crane or parallel loading dock. Never attempt to manually lift the unit.
- iii. To move the container over rough surfaces, or lift the container, attach an appropriate sling to the lifting points cut into the welded support post, and use a portable lifting device that will handle the weight of the container and its contents.

***Freight Damage Precautions:***

*Any freight damage claims are your responsibility. Cryogenic liquid containers are delivered to your carrier from Taylor-Wharton's dock in new condition. When you receive our product, you may expect it to be in the same condition. For your own protection, take time to visually inspect each shipment in the presence of the carrier's agent before you accept delivery. If any damage is observed, make an appropriate notation on the freight bill. Then, ask the driver to sign the notation before you receive the equipment. You should decline to accept containers that show damage which may affect serviceability.*

## SPECIFICATIONS

	XL-45	XL-50	XL-55
<b>Dimensions</b>			
Diameter, in (mm)	20 (508)	20 (508)	20 (508)
Height, in (mm)			
RND BASE	60 (1525)	62.3 (1582)	65 (1650)
SQ. BASE	NIL	NIL	NIL
<b>Weight Empty (Nominal), lb (kg)</b>			
RND BASE	244 (111)	253 (115)	262 (119)
SQ. BASE	NIL	NIL	NIL
<b>Capacity, Gross, Liters</b>	180	193	210
<b>Capacity, Useable Liquid, Liters</b>	169	181	200
<b>Weight of Contents Maximum</b>			
Base on DOT Rated Service Pressure			
lb. (kg)			
Oxygen	389 (176)	416 (189)	454 (206)
Nitrogen	274 (124)	293 (133)	319 (145)
Argon	472 (214)	505 (229)	551 (250)
<b>Normal Evaporation Rate*</b>			
(% Capacity per Day)			
Oxygen	1.2%	1.1%	1.1%
Nitrogen	1.9%	1.8%	1.7%
Argon	1.2%	1.1%	1.1%
<b>Gas Flow Rate @ NTP (STP)**</b>			
cfh (cu. m/h)			
Oxygen	350 (9.2)	350 (9.2)	350 (9.2)
Nitrogen	350 (9.2)	350 (9.2)	350 (9.2)
Argon	350 (9.2)	350 (9.2)	350 (9.2)
<b>Relief Valve Setting, psig (bar/kPa)</b>	230 (15.9 / 1590)	230 (15.9 / 1590)	230 (15.9 / 1590)
<b>Inner Container Bursting Disc, Psig (bar / kPa)</b>	360 (24.8 / 2480)	360 (24.8 / 2480)	360 (24.8 / 2480)
<b>Dual Pressure Building/ Economizer Regulator***</b>			
Pressure Building Setting, psig (bar / kPa)	125 (8.6 / 862)	125 (8.6 / 862)	125 (8.6 / 862)
Economizer Setting, psig (bar / kPa)	145 (10 / 1000)	145 (10 / 1000)	145 (10 / 1000)
<b>Design Specifications</b>			
TC	4LM	4LM	4LM
DOT	4L	4L	4L
<b>Gaseous Capacity</b>			
Base on DOT Rated Service Pressure			
@ NTP, cu.ft. (STP, cu.m)			
Oxygen	4688 (123)	5025 (132)	5484 (144)
Nitrogen	3771 (99)	4046 (106)	4402 (116)
Argon	4558 (120)	4884 (128)	5331 (140)

**SPECIFICATIONS (continue)**

	XL60 (TMXL230)	XL-65	XL70
<b>Dimensions</b>			
Diameter, in (mm)	26 (660)	20 (508)	26 (660)
Height, in (mm)			
RND BASE	56.10 (1425)	57.5 (1460)	61.5 (1562)
SQ. BASE	61.50 (1563)	58.0 (1473)	62.0 (1575)
Weight Empty (Nominal), lb (kg)			
RND BASE	326 (148)	335 (152)	344 (156)
SQ. BASE	390 (177)	368 (167)	376 (171)
<b>Capacity, Gross, Liters</b>	240	250	280
<b>Capacity, Useable Liquid, Liters</b>	230	240	265
<b>Weight of Contents Maximum</b>			
Base on DOT Rated Service Pressure			
lb. (kg)			
Oxygen	517 (235)	543 (246)	606 (275)
Nitrogen	364 (166)	382 (173)	426 (193)
Argon	628 (286)	659 (299)	735 (333)
<b>Normal Evaporation Rate*</b>			
(% Capacity per Day)			
Oxygen	0.9%	1.1%	1.0%
Nitrogen	1.4%	1.7%	1.8%
Argon	0.9%	1.1%	1.0%
<b>Gas Flow Rate @ NTP (STP)**</b>			
cfh (cu. m/h)			
Oxygen	350 (9.2)	350 (9.2)	350 (9.2)
Nitrogen	350 (9.2)	350 (9.2)	350 (9.2)
Argon	350 (9.2)	350 (9.2)	350 (9.2)
<b>Relief Valve Setting, psig (bar/kPa)</b>	230 (15.9 / 1590)	230 (15.9 / 1590)	230 (15.9 / 1590)
<b>Inner Container Bursting Disc,</b>			
<b>Psig (bar / kPa)</b>	360 (24.8 / 2480)	360 (24.8 / 2480)	360 (24.8 / 2480)
<b>Dual Pressure Building/ Economizer Regulator***</b>			
Pressure Building Setting, psig (bar / kPa)	125 (8.6 / 862)	125 (8.6 / 862)	125 (8.6 / 862)
Economizer Setting, psig (bar / kPa)	145 (10 / 1000)	145 (10 / 1000)	145 (10 / 1000)
<b>Design Specifications</b>			
TC	4LM	4LM	4LM
DOT	4L	4L	4L
<b>Gaseous Capacity</b>			
Base on DOT Rated Service Pressure			
@ NTP, cu.ft. (STP, cu.m)			
Oxygen	6245 (164)	6558 (186)	7316 (207)
Nitrogen	5023 (133)	5275 (149)	5885 (167)
Argon	6077 (160)	6379 (181)	7116 (202)

Specification are subject to change without notice.

\*Vent N.E.R. based on Useable Liquid Capacity.

\*\*Container pressure at or above factory Dual Pressure Building/Economizer Regulator setting.

\*\*\*Regulator has a pressure delta of 20 psig (1.4bar/138kPa)

## OPERATION

The XL-45 will store up to 169 liters of product; the XL-50 up to 181 liters, the XL-55 up to 200 liters, the XL-60 up to 230 liters, the XL-65 up to 240 liters, and 265 liters for XL-70. All these cylinders can deliver either liquid or gas. The following component and circuit descriptions are pertinent to the operation of all the containers and should be read before attempting operation. Components may be identified on the Component Location illustration.

## COMPONENT DESCRIPTIONS

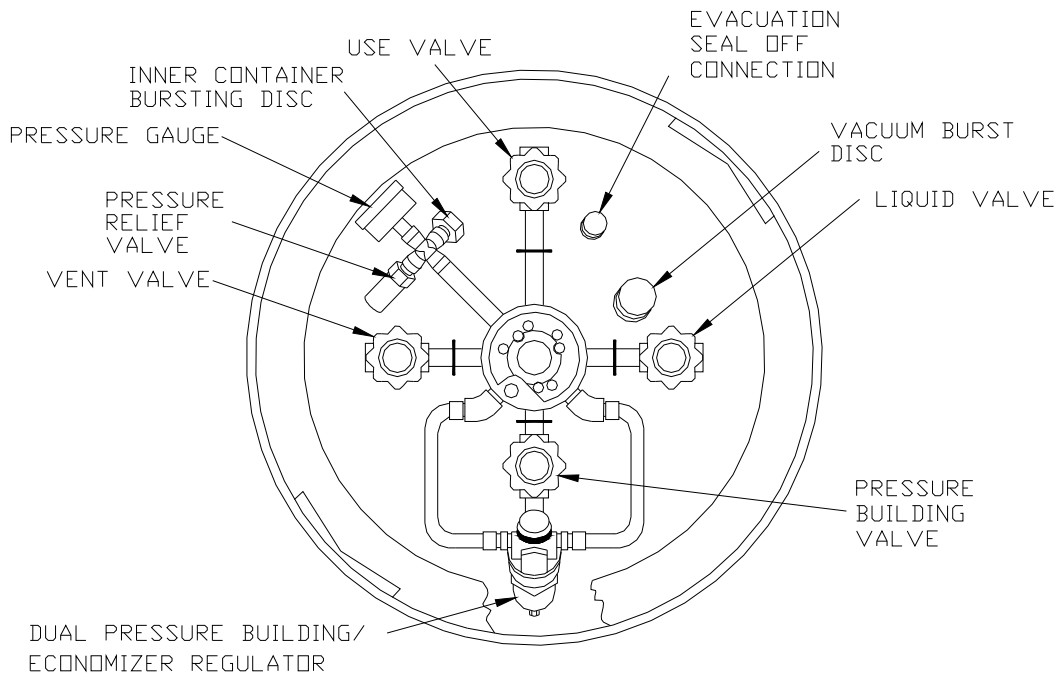

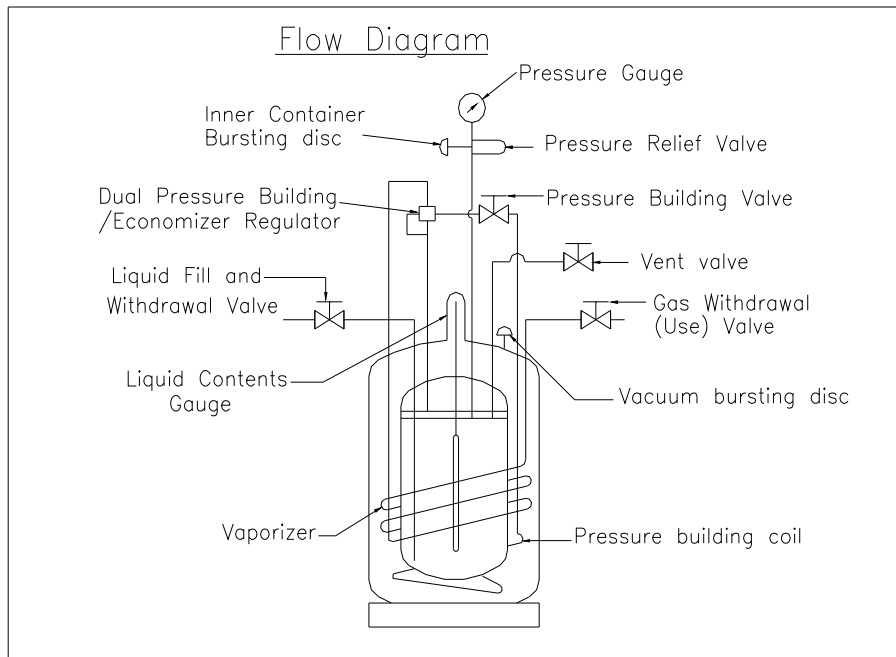

### Internal Vaporizer

A liquid container for gas service must have an internal heat exchanger that functions as a gas vaporizer coil to convert liquid product to gas continuously during withdrawal. The cylinder utilizes an internal heat exchanger that is inside the vacuum space attached to the container's outer casing. It provides a means of introducing heat from outside container's insulated jacket, to vaporize liquid as gaseous product is withdrawn. The capacity of this circuit is sufficient to vaporize product flow rates up to 350 cfh @ NTP (9.2 cu.m/h @STP). If greater continuous demand is put on the vaporizer, an external vaporizer should be added to properly warm the gas and avoid malfunction, or damage, to gas regulator, hoses, and other downstream components.

### Pressure Building

A Pressure Building circuit is used to ensure sufficient driving pressure during high withdrawal periods. This function is actuated by opening a hand valve that create a path from the liquid in the bottom of the container, through the Preeure Building Regulator, to the gas space in the top. When the pressure buiding valve is open, and the container pressure is below the pressure building regulatoe setting, liquid taken from the inner container is vaporized in the heat exchanger which is inside the outer casing. The expanding gas is fed into the upper section of the container to build pressure. The resulting pressure will drive either the liquid or gas delivery system.

Pressure Building is not normally required unless container pressure drops below the gas output pressure desired. If, for example, the container pressure gauge reads 75 psig (5 bar/517kPa), and your gas pressure requirement is 100 psig (6.9 bar/690 kPa), the pressure building valve may be opened to build container pressure to 125 psig (8.6 bar/862 kPa).



### **Economizer**

An economizer circuit withdraws gas preferentially from the head space over the liquid in the container-gas that otherwise lost to venting. Excess pressure in the head space of the container is relief by allowing gas to flow from this area direct to the USE valve outlet while gas is withdrawn from the container; yet normal operating pressure is preserved to ensure uninterrupted product delivery. The economizer is automatic and require no operator attention.

***Note: The economizer and pressure building fuctions are controlled by a single dual action regulator. The pressure delta between the pressure building setpoint and the economizer setpoint is approximately 20 psig (1.4 bar/138 kPa). This delta cannot be altered.***

### **The USE valve**

This valve controls the gas outlet that allows product withdrawal through the internal vaporizer. It has the required CGA connection that matches the gas service for which the container is configured.

### **The LIQUID valve**

Liquid product is added or withdrawn from the container through the connection controlled by this valve. It has the CGA fitting that is required for liquid line connections. The valve is opened for fill or liquid withdrawal after connecting a transfer hose with compatible fittings to the LIQUID line connection.

### **The PRESSURE BUILDING Valve**

This valve isolates the liquid in the bottom of the container to the Dual Pressure Building/Economizer Regulator. This valve must be open to build pressure inside the container.

### **The VENT Valve**

This valve controls a line into the head space of the container. It is used during the fill process. The VENT valve act as fill point during the pump transfer, or to vent the head space area while liquid is filling the inner container during a pressure transfer fill through the LIQUID valve.

### **The Pressure Gauge**

The pressure gauge displays the internal container pressure in pound-per-square-inch or in kilo Pascal.

### **The Full View Contents Gauge**

The container contents gauge is a float type lequid level sensor that indicates container liquid content through a magnatic coupling to a yellow indicator band. This gauge is an indication of approximate container contents only and should not be used for filling; liquid cylinder should be filled by weight.

### **Relief Devices**

These cylinders have a gas service relief valve and inner container bursting disc with setting of 230 psig (16 bar/1586 kPa) and 360 psig (24.8 bar/248 kPa) respectively. A 22 psig (1.5 bar/152 kPa) relief valve is available for liquid delivery applications.

**RELIEF VALVES AND RECOMMENDED REGULATOR SETTING**

<b>Relief Valve Setting</b>	<b>Pressure Building Setting</b>	<b>Economizer Setting</b>	<b>Normal Operating Range</b>
22 psig 1.5 bar 152 kPa	N/A N/A N/A	N/A N/A N/A	0-22 psig 0-1.5 bar 0-152 kPa
230 psig 16 bar 1586 kPa	125 psig 8.6 bar 862 kPa	145 psig 10 bar 1000 kPa	75-175 psig 5-12 bar 517-1207 kPa

**PURGE PROCEDURE**

Before placing the cylinder in service, determine the level of purity in the pressure vessel. If the pressure vessel contents purity is unacceptable, perform a product purge to reduce contaminants. The following procedure is recommended for the applications:

1. Attach the liquid purge product source to the LIQUID VALVE. Approximately 40 psig product delivery pressure should be achieved. *The positive pressure must always be maintained in the cylinder during purge procedure to prevent drawing atmospheric contaminants back into the cylinder.*
2. Closed all valves. *Before venting to atmosphere ensure that such venting is allowed by all applicable site regulations and codes.*
3. Open VENT VALVE and vent the inner vessel to 5 psig (34kPa) as indicated on the PRESSURE GAUGE. Close VENT VALVE.
4. Open the USE VALVE slightly to allow the liquid to flow slowly into the bottom of the cylinder. Flow must be gradual enough to allow the liquid to vaporize so that pressure build up in the inner cylinder to flood the exposed section of line, then close valve.
5. When cylinder PRESSURE GAUGE indicated maximum desire purge pressure, close the liquid supply source. When all product in the fill hose has vaporized close the LIQUID VALVE. Then relief hose pressure by opening a hose drain valve on the supply vessel.
6. After 1 hour open the LIQUID VALVE then drain all the liquid from the cylinder.
7. When only vapor exits, close all valves.
8. After all liquid has drained from the cylinder, open VENT VALVE and vent for 2 minutes with cylinder pressure at 40 psig.
9. Repeat purge procedure 2 through 8 until an acceptable product purity is achieved.
10. After completion of cylinder purge, make sure that all valves are closed.

**Pressure Building Rate Graph**

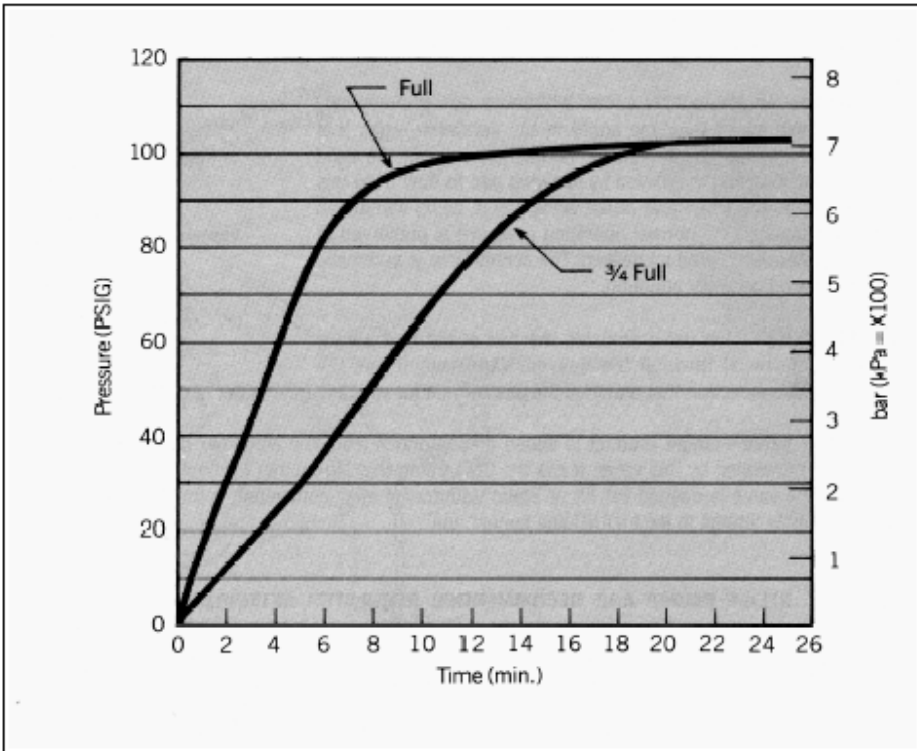

**Vaporizer Performance Graph**

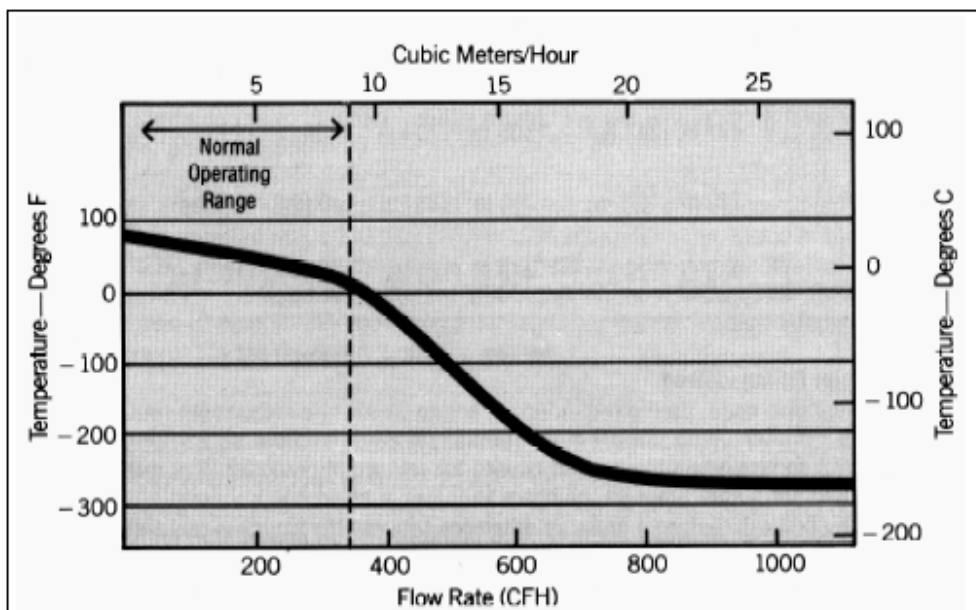

## WITHDRAWAL GAS FROM THE CONTAINER

To withdraw gas from XL-45/50/55/60/65 and XL-70 connect a suitable pressure regulator to the USE connection, and the output of the regulator to your external equipment. Then open the USE and the PRESSURE BUILDING valves. When the container pressure reaches 125 psig (8.6 bar/862 kPa), set the pressure regulator for the desired delivery pressure.

Increasing Gas Supply Capacity –Two or more liquid containers may be manifolded together. Accessory manifolds are available for use in creating a higher capacity gas supply system. The XL-45/50/55/60/65/70 can supply gas at flowrates up to 350 cfh @ NTP (9.2 cu.m/h @STP) using only its internal vaporizer. At low flowrates, the gas supplied will be at nearly ambient temperature. As the demand is increased, the gas will become proportionately colder. If greater vaporizing capacity is required, an accessory external vaporizer is available. When an external vaporizer is used, it must be connected to the USE valve and the regulator moved to the output of the external vaporizer.

**CAUTION: When withdrawing gas from the cylinder, the capacity of the internal vaporizer can be exceeded. If gas is withdrawn at rates greater than the vaporizer capacity, liquid or very cold gas will be discharged. Severe damage to external equipment could result from the extreme cold.**

## WITHDRAWAL LIQUID FROM THE CONTAINER

Attach a transfer hose to the LIQUID connection and open the adjacent LIQUID valve. The pressure in the container will drive liquid product out the valve as long as the container pressure exceeds that of the receiver.

The rate of liquid withdrawal from these containers is variable depending on the gas phase pressure and the saturation of the liquid.

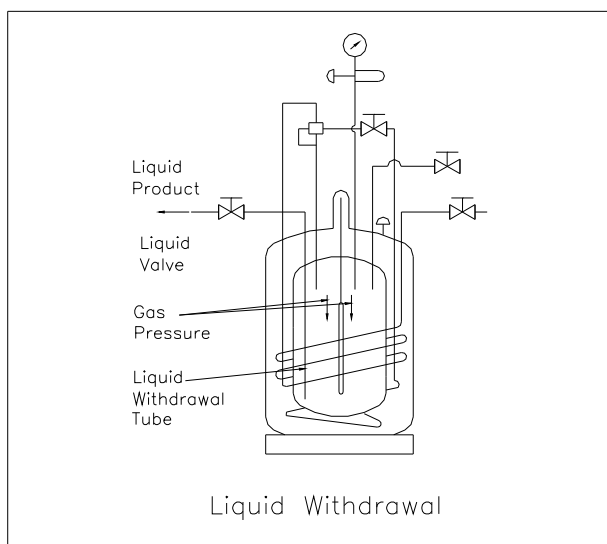

**CAUTION: To avoid contamination, close the LIQUID valve on an empty container before disconnecting the transfer line.**

## FILLING THE CONTAINER

Cryogenic liquid containers must always be filled by weight to ensure there is enough gas head space (ulage) for liquid to expand as it warms. Using the procedure below, first determine the proper filled weight of each container. The weight derived is then used in either the Pump Transfer or Pressure Transfer filling procedures that follow.

### Determine Proper Fill Weight

1. Visually inspect the container. Do not attempt to fill containers with broken or missing components.
2. Move the container to a filling station scale and weight it both with, and without, the fill hose attached to determine the weight of the fill line assembly. The difference is the fill line weight.
3. To determine the weight at which the fill should be stopped, add the desired filling weight (from the table below), the transfer line weight, and the Tare Weight from the container's data plate.

### FILLING WEIGHTS

	XL-45	XL-50	XL-55	XL-60	XL-65	XL-70
ARGON	471 lb. (214 kg)	506 lb. (235 kg)	540 lb. (245 kg)	628 lb. (286 kg)	659 lb. (299 kg)	735 lb. (333 kg)
NITROGEN	273 lb. (127 kg)	293 lb. (133 kg)	313 lb. (142 kg)	364 lb. (166 kg)	382 lb. (173 kg)	426 lb. (193 kg)
OXYGEN	388 lb. (176 kg)	417 lb. (189 kg)	445 lb. (202 kg)	517 lb. (235 kg)	543 lb. (246 kg)	606 lb. (275 kg)

### Pressure Transfer Filling

Filling a liquid cylinder using the pressure transfer method is common for 22 psig (1.5 bar/152 kPa) service where the product is used for refrigerant purposes. This method may also be used for higher pressure cylinders to increase liquid holding time. A fill is accomplished by first establishing a pressure difference between the source vessel and the XL-45/50/55/60/65/70 (higher pressure at the bulk vessel). The pressure differential will then push the liquid from the storage vessel to the container being filled. This method is employed when no transfer pump system is available, or is a greater control over liquid temperature is desired.

Filling the container is accomplished through the LIQUID valve while the VENT valve is open or partially open to control product pressure. Careful control of pressure will control the amount of heat retained in the liquid. Lower pressure results in colder liquid transferred to the container and increases, or lengthens, product holding time.

**Pressure Transfer Filling Procedure (Low Pressure Source)-** Once you have determined the proper full weight for a container, connect a transfer hose to the LIQUID fitting from a low- pressure source of liquid.

1. Open the supply valve. Then, on the XL-45/50/55/60/65/70, open the LIQUID and VENT valves to begin the fill.
2. During the fill, monitor the container pressure and maintain a pressure of 10-15 psig (0.7-1 bar/69-103 kPa) by throttling the VENT valve.
3. When full weight is reached, closed both the LIQUID and the VENT valves.
4. Close the liquid supply valve and open the dump valve on fill line assembly.
5. Disconnect the fill line from the container and remove the container from the scale.

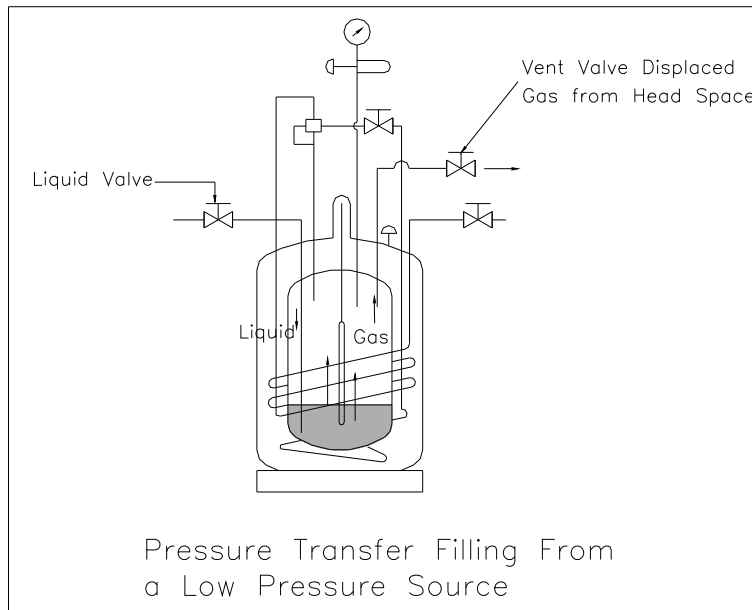

### Pump Transfer Filling Method

When a pump is used for filling liquid containers, the fill may be accomplished through either the VENT valve or LIQUID valve. Filling through the VENT valve recondenses gas in the area over the liquid in the cylinder and reduces product loss during the filling. This method will also result in liquid near the saturation temperature of the supply vessel. Filling through the LIQUID valve may provide colder liquid and longer holding time before the liquid warms to the point where the venting begins, but will require more frequent venting and greater product loss.

**Pump Transfer Filling Procedure** - This method applies only to containers in gas service that are equipped with a 230 psig (16 bar/1586 kPa), 350 psig (24 bar/2413 kPa) or 500 psig (34 bar/3447 kPa) relief valve. Liquid is admitted through the VENT valve and recondenses gas in the head space during the fill. The fill line is connected from the liquid supply to the VENT valve on the cylinder. Both the fill line and the container should be precooled prior to beginning the fill process. Proper full weight is determined by the previously explained method.

1. Open the supply valve. Then, on the container being filled, open only the VENT valve to begin the fill. Start the pump at this time.

2. Observe the container pressure closely. If the pressure approaches the relief valve setting (or the pump pressure rating) stop the fill process at the supply, and open the fill line dump valve to vent excess pressure. As soon as the pressure has dropped to a level that will allow you to resume the fill, close the dump valve and restart the pump (or reopen the supply valve).
3. When full weight is reached, close the VENT valve. Stop pump (where applicable), close liquid supply valve and open the dump valve on fill line assembly to vent trapped liquid.
4. Disconnect the fill line from the container and remove the container from the scale.

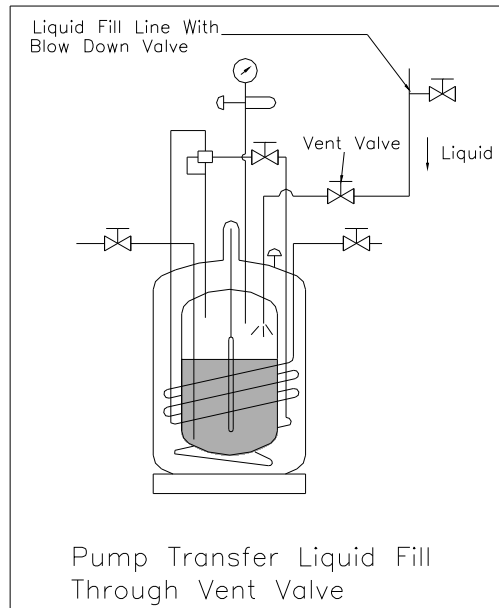

### Fill Hose Kits

Taylor-Wharton fill hose kits for the XL-45/50/55/60/65/70 are designed to transfer specific liquefied gases to, or from, the containers. These accessories are comprised of a Fill Tee Assembly and a Fill Hose. Cryogenic transfer hoses are constructed of stainless steel for the transfer of cryogenic liquids, and are available in four or six feet (1.2 or 1.8 m) lengths with 3/8 in. NPT fitting on one end and CGA service-specific female fittings on the other. A fill Tee Assembly consists of a cross fitting with a CGA end fitting, relief valve and manual dump valve.

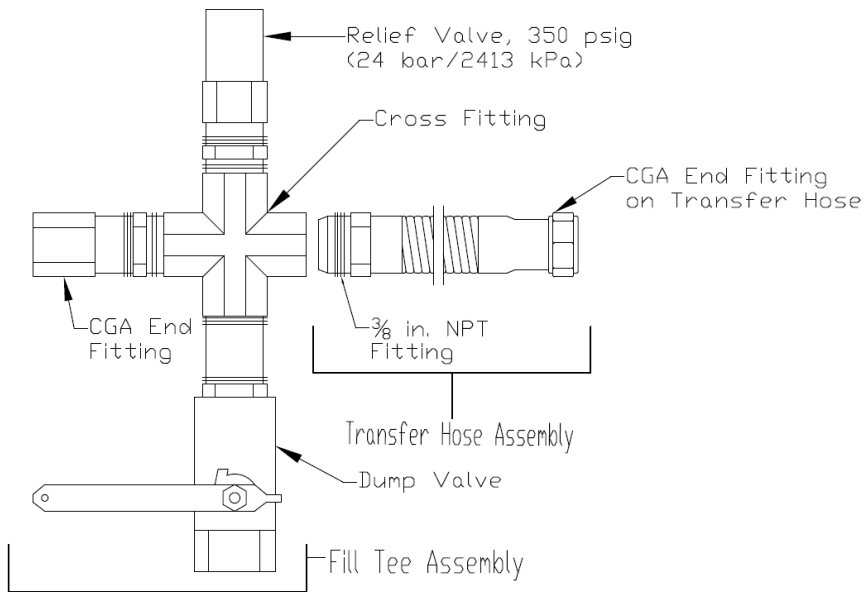

In use, the CGA Tailpiece couples to the fill connection on the container being filled. The Relief vents pressure over 350 psig (24 bar/2413 kPa) that builds up in the fill line due to trapped liquid. The Dump Valve is used to allow the operator to blow-down the receiving container during a pump fill, or to relieve residual pressure from expanding liquid trapped in the line before disconnecting the fill line.

Fill kits are available with different combinations of hose length and fittings for specific gas service. The following chart identifies the available transfer hoses and fill tee assemblies.

### TRANSFER HOSE CHART

Description (Service/Hose Length)	Cylinder Connection(s)	End Fittings	Part Number
<b>Inert (N<sub>2</sub>,Ar) Service</b>			
4 ft. (1.2m) Stainless Steel	LIQUID or VENT Valve	CGA 295 to 3/8in. NPT	1700-9C65
6 ft. (1.8m) Stainless Steel	LIQUID or VENT Valve	CGA 295 to 3/8in. NPT	1600-9C66
6 ft. (1.8m) Stainless steel	USE Valve	CGA 580 to 3/8in. NPT	GL50-9C65
<b>Oxygen Service</b>			
6 ft. (1.8m) Stainless Steel	LIQUID or VENT Valve	CGA 440 to 3/8in. NPT	GL50-8C53
6 ft. (1.8m) Stainless steel	USE Valve	CGA 540 to 3/8in. NPT	GL50-8C56

### VENT TEE CHART

The vent tee connects to a transfer hose to complete a fill line kit. Each assembly includes a 3/8 in. Pipe connector to CGA fitting with 350 psig (24 bar/2413 kPa) relief valve, and a ball-type dump valve.

Service	CGA Connection	Part Number
Inert (N <sub>2</sub> ,Ar)	CGA 295	GL50-8C60



## MAINTENANCE PROCEDURE

Read the Safety Precautions in the front of this manual before attempting any repairs on these containers. And also follow these additional safety guidelines while performing container maintenance.

**Never work on a pressurized container.** Open the vent valve as standard practice during maintenance to guard against pressure build-up from residual liquid.

**Use only repair parts cleaned for oxygen service.** Be certain your tools are free of oil and grease. This is a good maintenance practice, and helps to ensure you do not create a combustion hazard when working on containers for oxygen or nitrous oxide service.

**Leak test connections after every repair.** Pressurize the container with an appropriate inert gas for leak testing. Use only approved leak test solutions and follow the manufacturer's recommendations. "Snoop" Liquid Detector is one approved solution.

***WARNING: For O2 System User: Residue of leak detectors solutions can be flammable. All surfaces to which the leak detector solutions have been applied must be adequately rinsed with portable water to remove all traces of residue. Ference CGA G-4. Section 4.9.***

## CONVERTING A CONTAINER TO A DIFFERENT GAS SERVICE

XL-45/50/55/60/65/70 Cylinders may be converted from one service to another within the confines of the argon, nitrogen, and oxygen service for which the containers are designed. Conversion consists of changing the end connections at the USE, LIQUID, and VENT valves; then changing the liquid level gauge snap on indicator; and revising product decals. Parts are available in kit form for each gas service as illustrated in the following table.

### Service Change Procedure

Before removing any parts, empty the container and open the vent valve to prevent any pressure build-up in the unit.

1. Remove the LIQUID, VENT, and USE end fittings, one at a time, with standard wrenches. Install new fittings from the Gas Service Change Kit, using Teflon tape or another oxygen compatible thread sealant.
2. Remove the protective cover over the liquid level gauge. Replace the snap-on content scale with the one for the new gas service from the service change kit, then reinstall the protective cover.
3. Install new fittings for the USE, VENT, and LIQUID connections from the Gas Service Change Kit. Leak test the fittings you just replaced, and change the gas service decals to complete the conversion.

***CAUTION:***  
***When changing gas service, install the proper fitting- DO NOT use adapters. The following procedures address the physical changes to the container only. For detailed procedures on the decontamination of the container itself, refer CGA pamphlet C-10 "Changes of Service for Cylinders including Procedures for Inspection and Contamination Removal."***

### GAS SERVICE CHANGE KITS

Kit Part No.	Gas Service	Valve Name	Connection Designation
GL50-8C35	Oxygen	LIQUID VENT USE	CGA 440 CGA 440 CGA 540
GL50-8C30	Nitrogen	LIQUID VENT USE	CGA 295 CGA 295 CGA 580
GL50-8C31	Argon	LIQUID VENT USE	CGA 295 CGA 295 CGA 580

### **REGULATOR MAINTENANCE**

A dual stage, spring loaded regulator is employed for the pressure building/economizer circuit. This regulator can be adjusted on the container, replaced, or checked and adjusted off the container in a readily fabricated bench adjustment fixture.

#### **Regulator Adjustment- On container**

1. Fill the container with appropriate liquid product.
2. Open the Pressure Building Valve and allow the container pressure to stabilize for about an hour. Note the point where the pressure stabilizes.
3. Adjust the screw on the top of the regulator to raise or lower the pressure to the desired point. When decreasing the setting, the pressure building valve must be closed and the container vented to a lower pressure. Then repeat step 2 in order to observe the change.

**Note: One clockwise turn of the adjustment will raise the set point by approximately 30 psig (2 bar /207 kPa). See the chart below to determine the range of adjustment for the regulator you are servicing. Do not attempt to set the regulator to a pressure outside of its design range.**

#### **REGULATOR ADJUSTMENT RANGES**

Part No.	Normal Setting`	Range	Delta
6999-9015	125 psig 8.6 bar 862 kPa	50 to 175 psig 3.4 to 12 bar 345 to 1207 kPa	20 psig 1.4 bar 138 kPa

#### **Regulator Removal or Replacement Procedure**

1. Close manual Pressure Building valve.
2. Vent the container to atmospheric pressure.
3. Loosen and remove both the tube connections on the pressure building and economizer side of the regulator.
4. Remove the regulator from the container by unscrewing the valve body and elbow from the output of the pressure building valve.
5. Repair the regulator and readjust its setpoint using the bench test setup.

6. To install a replacement or readjusted regulator, apply Teflon tape to the elbow on the container and thread the valve body onto the elbow.
7. Reconnect the tube connections to the regulator and tighten.
8. Pressurize the container and check it for leaks.

### Regulator Adjustment-Bench Procedure

Assemble the regulator adjustment fixture, and the regulator to be adjusted, as shown in the accompanying illustration.

1. Leak test joint between the high-pressure cylinder regulator and the dump valve. Joints must be leak free before proceeding.
2. Close the ON/OFF valve, and the dump valve.
3. Slightly open the high-pressure cylinder valve.
4. Set the high-pressure regulator above the desired set point for the Pressure Building setpoint.
5. Slowly open ON/OFF valve and observe the downstream pressure gauge.
6. When the regulator under test closes, the P.B. set point may be read on the downstream pressure gauge.
7. Close the ON/OFF valve, and open the Dump valve.
8. To reset the regulator, loosen the locknut on the adjusting screw. Raise the set point by turning the adjusting screw clockwise; lower the set point by turning the screw counterclockwise. After adjustment, repeat step 5 and 6 to check the setting before reinstalling the regulator on the liquid container.

**Note:** *The regulator has directional gas flow. The arrow on the regulator body must point in direction indicated in the Bench Adjustment Fixture illustration. The economizer portion of the regulator has already opened approximately 20 psig (1.4 bar/ 138 kPa) below the pressure building setpoint.*

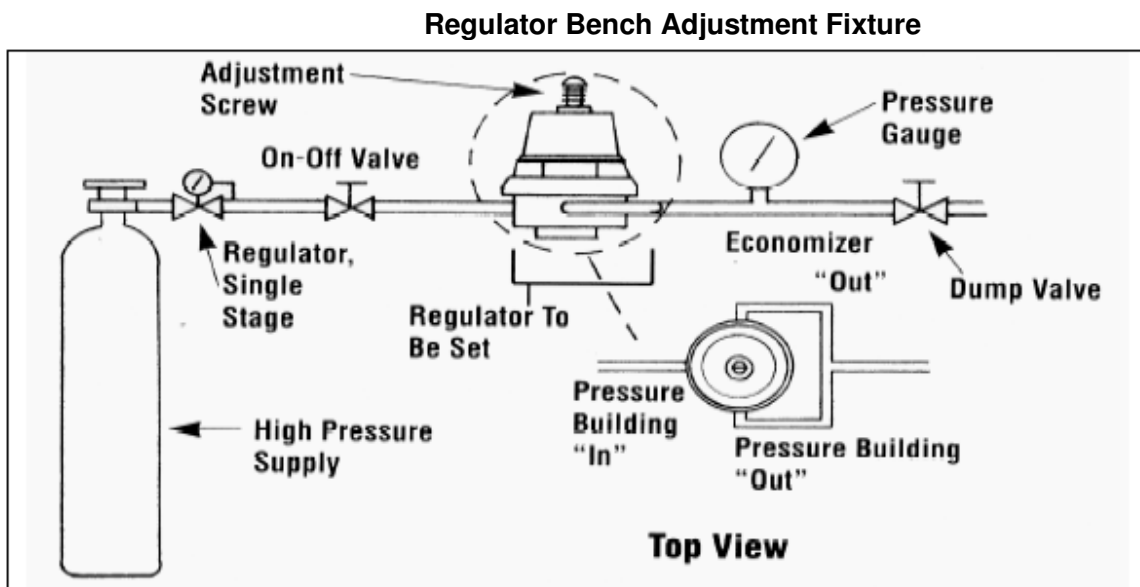

## CHECKING CONTAINER PERFORMANCE

Cryogenic containers are two containers, one within the other. The space between the containers acts as a highly efficient thermal barrier including high technology insulation, a vacuum, and a vacuum maintenance system. Each serves a very important part in the useful life of the container. The high technology is very effective in preventing radiated heat from entering the inner container. The vacuum prevents heat convection or conduction from reaching the inner container. Unfortunately, the perfect vacuum cannot be achieved since trace gas molecules begin to enter the vacuum space from the moment of manufacture. The vacuum maintenance system consists of materials which gather trace gas molecules from the vacuum space. The maintenance system can perform its function for years, but it has a limited capacity. When the vacuum maintenance system is saturated it can no longer maintain the vacuum integrity of the container. The change will be very gradual and may go unnoticed for several years. When the vacuum in the insulation space is no longer effective, the following symptoms may appear:

1. With liquid in the container and pressure building/vaporizer coil not in use, the outer casing will be much colder than comparative container.
2. Frost, indicating the liquid level, may be visible on the outer casing of the container.
3. The container may appear to "sweat" if the air surrounding the container is hot and humid.
4. The relief valve will open continuously until the container is empty.
5. The container will hold pressure for several days but will not hold liquid.

## NER Testing

If a loss of vacuum integrity is suspected, the container's Normal Evaporation Rate (NER) should be checked. The test measures the actual product lost over time so you can compare the results obtained to the NER value in the SPECIFICATIONS table. A test period of 48 hours is recommended, after the container is allowed to stabilize, but the formula given produces a Daily NER over any time period.

1. Fill the container with 150 pounds (68 kg) of liquid nitrogen.
2. Close the LIQUID valve and the PRESSURE BUILDING valve, leave the VENT valve open and allow it to remain open during test.
3. Allow the container to stabilize for 24 hours, then reweigh it. Record the weight, time, and date.
4. Reweigh 48 hours later. The test is most effective if container is not moved during this period. Record the second test date, time, and weight.

The following calculation will provide the actual Normal Evaporation Rate in pounds-per-day. Daily normal evaporation is simply half the loss over 48 hours.

$$\text{Daily NER} = \frac{[\text{Weight (step 3)} - \text{Weight (step 4)}]}{[\text{Time between Step 3 and Step 4 in hours}]} \times 24$$

Compare the results of your test to the "as manufactured" NER value in the SPECIFICATIONS section of this manual. A container in service should maintain an NER value of less than two times the new specification. Any test result greater than two times the listed value is indicative of a failed, or failing, vacuum. If NER is found to be high, contact Taylor-Wharton Customer Service.

## FULL VIEW CONTENTS GAUGE MAINTENANCE

The content of these containers is measured with Full View Contents Gauge. The device consists of the gauge assembly beneath a clear plastic protective cover. When the gauge is assembled, a snap on level indicator is magnetically coupled to the top of a float rod and moves up and down with the changing level of the liquid in the container.

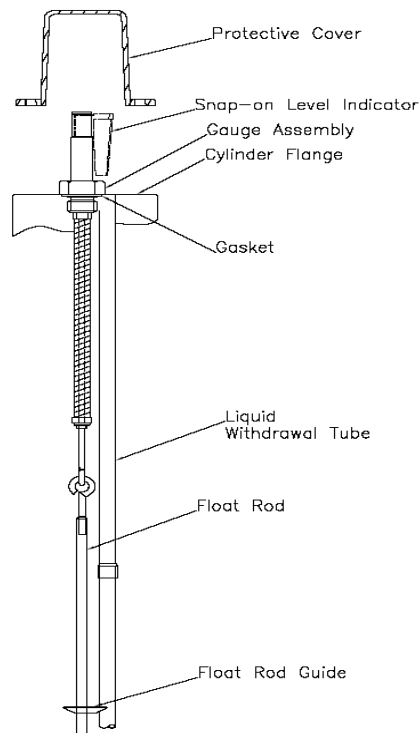

### Removing the Full View Contents Gauge

1. Vent all pressure from container.
2. Remove the protective cover by removing three bolts from the base of the cover.
3. Unscrew the gauge body using a wrench on hex fitting at base of the indicator.
4. Lift the entire gauge assembly free of the container. The gauge assembly is long and may be very cold. Gloves should be used to protect your skin.

**WARNING:** Cold surfaces should never be handled with bare skin. Use gloves and other protective clothing when performing this procedure.

### Contents Gauge Installation

Before installing a new gauge or repaired, inspect the gasket seals. If any damage is apparent, replace the gasket.

1. When inserting the gauge assembly, lower the float rod through the gauge opening until about 8 inches (203 mm) of the float rod remains above the container.

2. Grasp the clear cover portion of the gauge assembly with two fingers so that the assembly hangs free and "plumb."
3. Lower the assembly about 4 inches (102 mm) slowly and try to keep the rod in the center of the threaded entrance hole as you do. If you are careful during this portion of insertion, you will drop the float rod straight through the guide ring inside the cylinder.

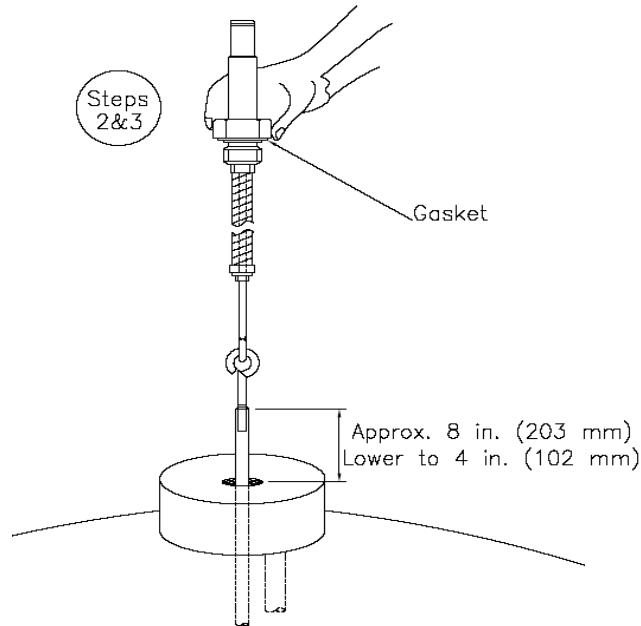

4. To confirm that the rod is correctly positioned in the cylinder, stop where you can still grasp the top of the rod and try to swing the lower end from side to side.

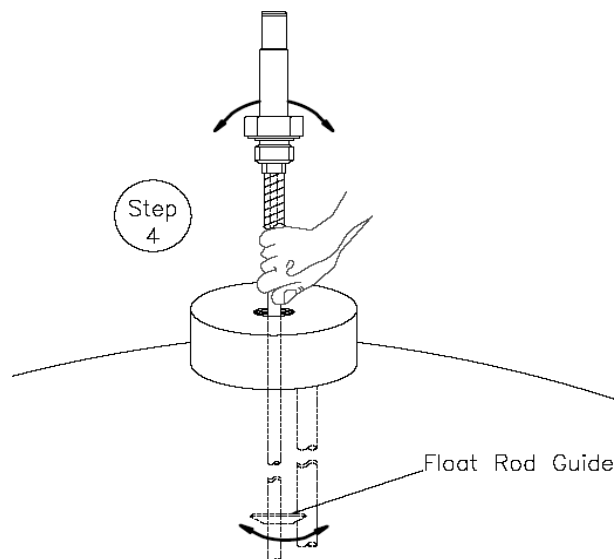

5. When the rod is engaged in the guide ring, the rod will be restricted to lower end movement of about ½” inches (12.7 mm); if the you can feel greater movement, withdraw the rod to the point where its top is 8 inches (203 mm) above the gauge opening and try again.
6. When you are satisfied that the float rod is correctly installed, lower the assembly the rest of the way into the container until the top portion threads can be engaged.
7. Screw the gauge in place and hand torque to about 20 ft lbs (2.8 kgf m). Leak check the connection of gauge to the flange.

**CAUTION:**

*When installing the gauge assembly, care must be taken to ensure that the float rod is inserted through “guide ring” located on the liquid withdrawal line inside the container. If the gauge does not engage this ring, the contents indication will be inaccurate, or the gauge may be damaged in use.*

### **HAND VALVE REPAIR**

Hand valves are an integral part of the container, and the valve bodies rarely need replacement. However, the handwheel and internal parts of the valves are renewable. The illustration below is a view of the valve replaceable part used on Taylor-Wharton liquid container.

#### **Valve Repair Kit Assembly**

Fits: 3/8 in Rego Globe valve.

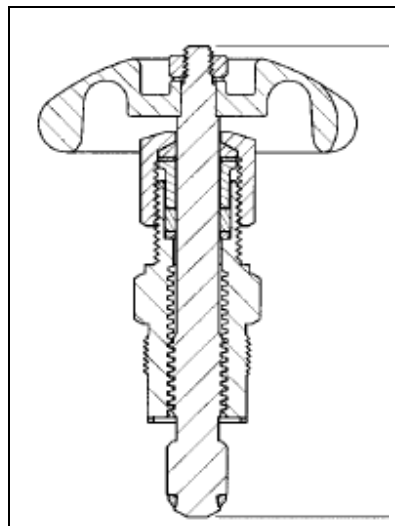

**KIT PARTS- Kit P/N 1750-9C35**

### Valve Disassembly Instructions

1. Open valve by turning Handwheel counterclockwise as far as it will go to release any trapped gas in the system.
2. Using a large adjustable wrench to hold valve body, remove Bonnet by turning counterclockwise with a 15/16-inches socket wrench that capable of developing at least 80 ft lbs (22 kgf m) torque.
3. Remove the handwheel assembly from the valve body and discard. Inspect body and clean if necessary; be sure interior and seal areas are free from dirt, residue and foreign particles.

**CAUTION:**  
*Do not apply force after valve is fully open.*  
*Do not scratch or mark internal surface of valve.*

### Valve Replacement Instructions

1. Thread Handwheel Assembly into valve body until properly seated.
2. Turn Handwheel completely clockwise to close valve. Re-pressurize container and leak check valve.

### **SHOCK MOUNT FOOT RING (XL-45/50/55)**

Item No.	Description	Part No.	Qty.
1	Rubber Shock Ring	XL50-4C18	1
2	Foot Ring	XL50-4C19	1
3	Hex Nut	6310-0135	4
4	Washer	6430-0125	4
5	Carriage Bolt	6620-0401	4

### **Shock Mount Foot Ring- ExplodedView**

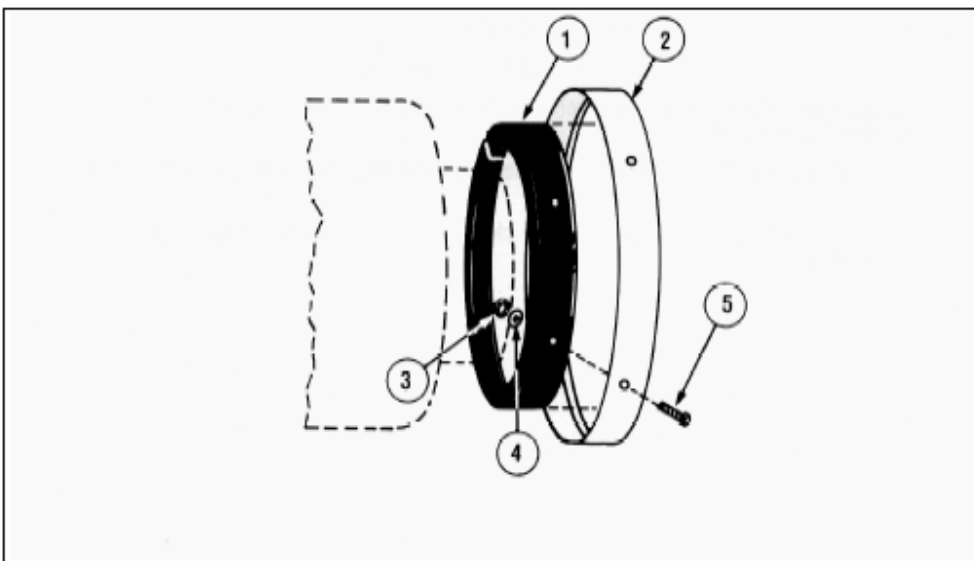



## Replacement of Shock Mount Foot Ring

1. Empty or transfer all contents of tank. Vent to atmospheric pressure.
2. Gently lay the container on its side and unbolt the four (4) carriage bolts that attached the foot ring and rubber ring to the tank.
3. Slide off the damaged foot ring and rubber shock ring.
4. Assemble rubber shock ring into new foot ring and force over shock mount ring on container. Use a rubber hammer to drive the rubber shock ring into place.
5. Using a ½ inch drill bit, drill holes through rubber so that the carriage bolt slides in smoothly.
6. The holes in foot ring must be position in alignment with holes in shock mount ring. Using the 4 bolts, washers and nuts, fasten the new parts to the container.
7. After securing the shock mount ring, gently lift the container to the upright position and inspect your work.

***Note: If the original Shock Mount Ring is badly damaged we recommend that an NER test is performed to ensure that no internal damage has resulted from the impact of the shock mount ring.***

## TROUBLESHOOTING

The following chart is provided to give you some guidance in determining the probable cause and suggested corrective action for some problems that may occur with cryogenic liquid containers. This chart is specifically tailored to your XL-45, XL-50, XL-55, XL-60, XL-65 or XL-70.

### TROUBLESHOOTING CHART

Symptom	Possible Cause	Corrective Action
Consistently low operating pressure.	<ol style="list-style-type: none"> <li>1. Relief valve open at low pressure.</li> <li>2. Economizer side of P.B./Economizer Regulator stuck open.</li> <li>3. Cold liquid.</li> </ol>	<ol style="list-style-type: none"> <li>1. Remove and replace relief valve.</li> <li>2. Remove and replace regulator</li> <li>3. Open pressure building valve. With P.B. inoperative, the container will build pressure over time, or an external pressure source can be used to pressurize container.</li> </ol>
No pressure shown on container pressure gauge.	<ol style="list-style-type: none"> <li>1. Bad container pressure gauge.</li> <li>2. Open inner container bursting disc.</li> <li>3. Leaks in valves or plumbing.</li> <li>4. Cold liquid.</li> </ol>	<ol style="list-style-type: none"> <li>1. Remove and replace bad gauge.</li> <li>2. Remove and replace bursting disc. Pressurize container and check relief valve operation.</li> <li>3. Leak test and repair leaks. For valve repairs, see Maintenance section.</li> <li>4. Open pressure building circuit.</li> </ol>
No pressure showing but container is full by weight.	<ol style="list-style-type: none"> <li>1. Broken pressure gauge.</li> <li>2. Vent valve open/P.B. valve closed.</li> <li>3. Faulty relief valve.</li> </ol>	<ol style="list-style-type: none"> <li>1. Replace pressure gauge.</li> <li>2. Close vent valve, open P.B valve.</li> <li>3. Replace relief valve.</li> </ol>
Container full by weight and Liquid Level Gauge but very low pressure.	<ol style="list-style-type: none"> <li>1. Liquid too cold.</li> <li>2. Possible leak in vent valve.</li> <li>3. Faulty relief valve</li> </ol>	<ol style="list-style-type: none"> <li>1. Open P.B. valve or allow to stand.</li> <li>2. Rebuild valve.</li> <li>3. Replace valve.</li> </ol>
Container is cold and may have ice or frost on outer casing. Will not hold liquid overnight. Relief valve is venting gas.	<ol style="list-style-type: none"> <li>1. Vacuum loss. Check NER.</li> </ol>	<ol style="list-style-type: none"> <li>1. Consult with Taylor-Wharton for course of action. Do not attempt to put additional liquid container.</li> </ol>

	2. Defective P.B./Economizer regulator.	2. Look for P.B coil pattern in ice. Close P.B. valve. Replace or reset regulator.
Ice formation on bottom of container when P.B. valve is closed.	1. Pressure building valve not closing properly. 2. Leak in pressure building system topworks.	1. Replace or rebuild valve. 2. Leak test piping connections and tighten fitting if needed.
Container vents through relief valve when in use.	Pressure Building/Economizer Regulator set above relief valve setting. Economizer side of regulator clogged or stuck open.	Remove and reset or replace regulator.
Container vents after fill but quits after awhile.	This may be caused by residual heat vaporizing some liquid inside container and is a normal condition.	Symptom should go away once container reaches operating temperature and the liquid reaches its saturation point at container operating pressure.
Container vent gas continuously through relief valve.	Heat leak may be too great.	Perform container performance evaluation test per Maintenance section to determine if container vacuum is adequate.
Level indicator stuck 1/2 full. Yellow indicator ring will not move.	Float rod stuck on or in float rod guide.	Reinstall. See Contents Gauge Installation section.
Level indicator at bottom of gauge. Container full of product.	Indicator disengaged from gauge rod. Caused by dropping the container.	Recouple indicator using re-engagement ring.

## REPLACEMENT PARTS

This replacement parts list includes a recommended inventory quantity which allows you to order parts on timely basis to keep all your XL-45/50/55/60/65/70 containers in service. When placing orders, please use the nomenclature and part numbers in this section.

### COMPONENT LOCATIONS

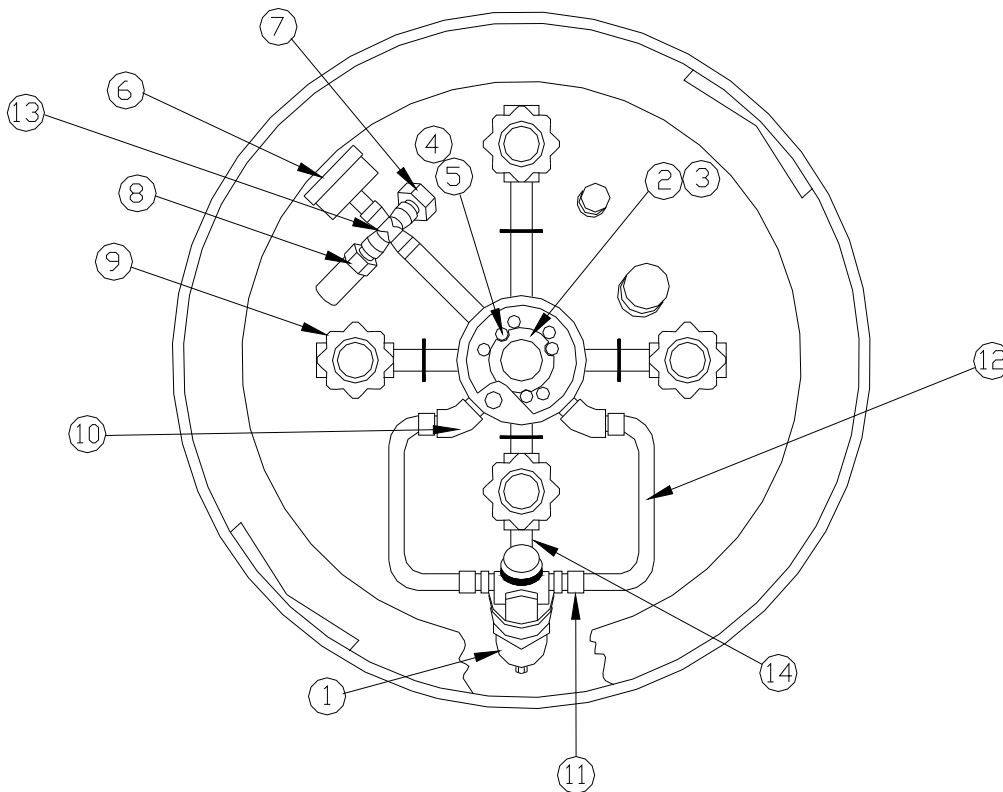

## ACCESSORIES

Accessories available for use with Taylor-Wharton XL-Series containers are:

- Manifold, Automatic and Manual
- Vaporizer adding up to 250 cfh (6.6 cu.m/h) each
- Transfer Hoses (O<sub>2</sub>, N<sub>2</sub>, and AR)
- Fill Tee Assemblies
- Container Hand Trucks
- Gas Service Changeover Kits
- Cryogenic Phase Separators

For additional information concerning the accessory of your choice, please consult the separate manuals on accessories or call Taylor-Wharton.

Index No.	Descriptions	Part No.	Recommended for 10 Units
1	Dual Regulator, pressure Building/Economizer 125 psig (8.6 bar/862 kPa)	6999-9015	2 Each
2	*Gasket, Glass Filled Teflon, Contents Gauge	7701-0083	5 Each
3	Liquid Level Indicator Inert Spring Float Rod (GL45) Float Rod (GL50/55) Float Rod (GL60/65) Float Rod (GL70) Nitrogen, indicator Scale Argon, indicator Scale Oxygen, indicator Scale	GL45-9C65 GL45-9C96 GL50-9C97 GL50-9C94 GL45-9C95 GL45-9C75 GL45-9C76 GL45-9C77	1 Each 1 Each 1 Each 1 Each 1 Each 4 Each 4 Each 4 Each
4	Screw, brass, 1/4inch-20 UNC x 5/8 inch	6114-1087	10 Each
5	Washer, Lock, 1/4 inch, stainless steel	6460-2025	10 Each
6	Gauge, Pressure 0-400 psig (0-28 bar/0-2758 kPa)	1700-9C10	2 Each
7	Safety Head, 380 psig (26 bar/2620 kPa)	1190-9C21	2 Each
8	Relief valve, 230 psig (16 bar/1586 kPa)  **22 psig (1.5 bar/152 kPa)	1700-9C39 (Rego) 6913-9070 (Generant) 1700-9069 (Rego) 6913-9069 (Generant)	5 Each  5 Each
9	Valve Repair Kit	1750-9C35	3 Each
10	Elbow, Male, Brass, 45°, 3/8in. ODT-comp x 1/4 in.	6814-9233	2 Each
11	Connector, Male, Brass, 3/8 in. ODT-comp x 1/4in. NPT-EXT	4570-1960	2 Each
12	Tube, P.B./Economizer Line	GL45-9C20	2 Each
13	Cross Assembly	GL55-9C29	2 Each
14	Elbow, Male, 45°, 3/8 in. NPT x 1/4 in. NPT	6814-9241	2 Each
15	USE (CGA 540)-oxygen USE (CGA 580)-argon/nitrogen LIQUID (CGA 440)- oxygen LIQUID (CGA 295)-argon/nitrogen VENT (CGA 440)-oxygen VENT (CGA 295)-argon/nitrogen *Decal, Warning *Decal, Nitrogen service *Decal, Oxygen service *Decal, Argon service *Decal, UN Number, Nitrogen *Decal, UN Number, Oxygen *Decal, UN Number, Argon	7114-0613 7114-0614 6514-8992 7355-4712 6514-8892 7355-4712 1700-9C07 GL55-9C51 GL55-9C52 GL55-9C53 GL55-9C63 GL55-9C64 GL55-9C65	5 Each 5 Each 5 Each 5 Each 5 Each 5 Each 4 Each A/R A/R A/R A/R A/R A/R

\*Not illustrated

\*\*Optional/Not illustrated

## COMPONENT FOR SQUARE BASED ASSEMBLY CONTAINER

Item No.	Description	Part No.	Recommended For 10 Units
1	Capscrew, Hex Head S.S, 1/2 In	6164-1753	10 each
2	Hex Nut, Nylon Insert	6331-1183	10 each
3	Handle	XL65-9C31	1 each
4	Flat Washer, S.S	6460-9024	10 each
5	Spring Washer, S.S	6460-9025	10 each
6	Flat Washer, Teflon	6160-9026	5 each
7	Caster, Swivel 5 in. Dia. Wheel C.S	7300-8090	5 each
	*Caster, Swivel 4 in. Dia. Wheel C.S	7300-9016	5 each
8	Caster, Rigid 5 in. Dia. Wheel C.S	7300-8089	5 each
9	Carriage Bolt S.S, 1.25 In. lg	6160-4766	10 each
10	Hex Head Capscrew 1.0 in. lg	6164-1133	10 each
11	Elastic Stop Nut S.S,	6368-9110	10 each

\*Used on the 5 caster base model.

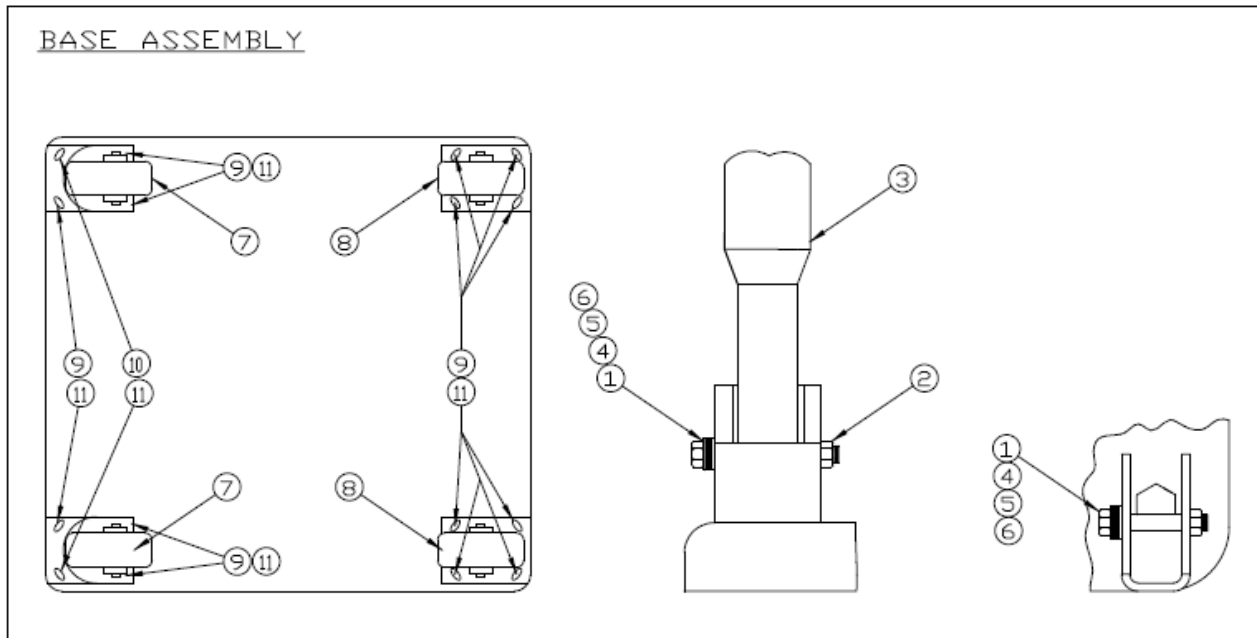

**QUALITY WARRANTY CERTIFICATES  
TAYLOR-WHARTON  
XL SERIES LIQUID CYLINDERS**

Taylor-Wharton warrants to the original purchaser that the internal structural support system of each XL Series Liquid Cylinder shall be free of defects in materials and workmanship for the life of the product if it is used and maintained according to Taylor-Wharton's published instructions. Taylor-Wharton warrants to the original purchaser of the following:

1. Vacuum Deterioration: The Vacuum system employed on each XL Series Liquid Cylinders is warranted to maintain thermal performance or Net Evaporation Rate (NER) within 10% of Taylor-Wharton's published specifications for a period of five years from date of shipment to the initial purchaser if the product is used and maintained according to Taylor-Wharton's published instructions.
2. Plumbing and control Valves: All components supplied by Taylor-Wharton and used on this product are warranted to be free from defects in materials and workmanship, in the normal service for which the product was manufactured, for a period of one year from the date of shipment to the original purchaser.

To validate the warranty, the purchaser must abide to the following: 1) Immediate discontinue use of the product to further investigation. 2) Purchaser to confirm that defect is due to either of the above by written notice to Taylor-Wharton within 48 hours after confirmation of a claimed defect. Upon receiving official notice, Taylor-Wharton will act as follows: 1) Were the defect is due to vacuum deterioration, Taylor-Wharton will ask the purchaser to return such product freight prepaid to Taylor-Wharton for further evaluation to validate to warranty claim. If the claimed defect is confirmed by Taylor-Wharton's inspection will submit a report to customer, at its option and as the purchaser's sole remedy, repair or replace such product or any component part thereof, or refund the original purchase price. If no defect is found or after correction of a confirmed defect, Taylor-Wharton will return the equipment at purchaser's expense. 2) If the defective is due to plumbing and control valves, Taylor-Wharton will require sending replacement parts to the purchaser for reinstallation by purchaser.

This warranty is voided by alterations or by repairs of others. Taylor-Wharton shall not be liable under this warranty, or otherwise, for defects caused by negligence, abuse or misuse of the product, corrosion, fire, heat, or the effects of normal wear. Any related components or other equipment manufactured by others which may be sold with

Taylor-Wharton's products are not covered by this warranty.

THIS WARRANTY IS IN LIEU OF ANY OTHER WARRANTIES, EXPRESS OR IMPLIED, INCLUDING ANY IMPLIED WARRANTY OF MERCHANTABILITY OR FITNESS FOR A PARTICULAR PURPOSE.

THE REMEDIES SET FORTH HEREIN ARE EXCLUSIVE. TAYLOR-WHARTON SHALL NOT BE LIABLE FOR ANY CONSEQUENTIAL, SPECIAL, OR INCIDENTAL DAMAGES RESULTING FROM THE DELIVERY, USE OR FAILURE OF THE PRODUCT (INCLUDING LOSS OF ANY MATERIAL STORED IN THE PRODUCT), OR FROM ANY OTHER CAUSE WHATSOEVER BY ACCEPTING DELIVERY OF THE PRODUCT SOLD HEREUNDER, THE PURCHASER ACKNOWLEDGES THAT THIS LIMITATION OF REMEDIES IS REASONABLE AND ENFORCEABLE. IN NO EVENT SHALL TAYLORWHARTON'S LIABILITY EXCEED THE PURCHASE PRICE FOR THE PRODUCT.



**Taylor-Wharton**  
Since 1742

Taylor-Wharton Malaysia Sdn Bhd (776817-V)  
Lot PT 5073, 5076 & 5077, Jalan Jangur 28/43,  
Hicom Industrial Estate, Section 28,  
40400 Shah Alam, Malaysia  
[www.taylor-wharton.com.my](http://www.taylor-wharton.com.my)