



Taylor-Wharton
Since 1742

Mobile Transfer Unit

Taylor-Wharton's rugged, lightweight liquid delivery tanks are designed for distributing liquefied gases to customer locations. The construction of each tank features superior high strength metal fabrication technology, advanced welding techniques and efficient cryogenic insulation.

Performance features and benefits include :

- Highly efficient piping design making operator control and maintenance easy.
- Larger fill lines increase liquid flow, minimizing fill times.
- High capacity pressure building coil facilitates fill of customer station and shorter transfer times.
- High performance vacuum insulation minimizes product losses.
- The pressure vessel is protected by a safety valve and bursting disc (Dual safety device optional).
- The MTU series tanks are equipped with a transverse baffle to minimize liquid load shifts.

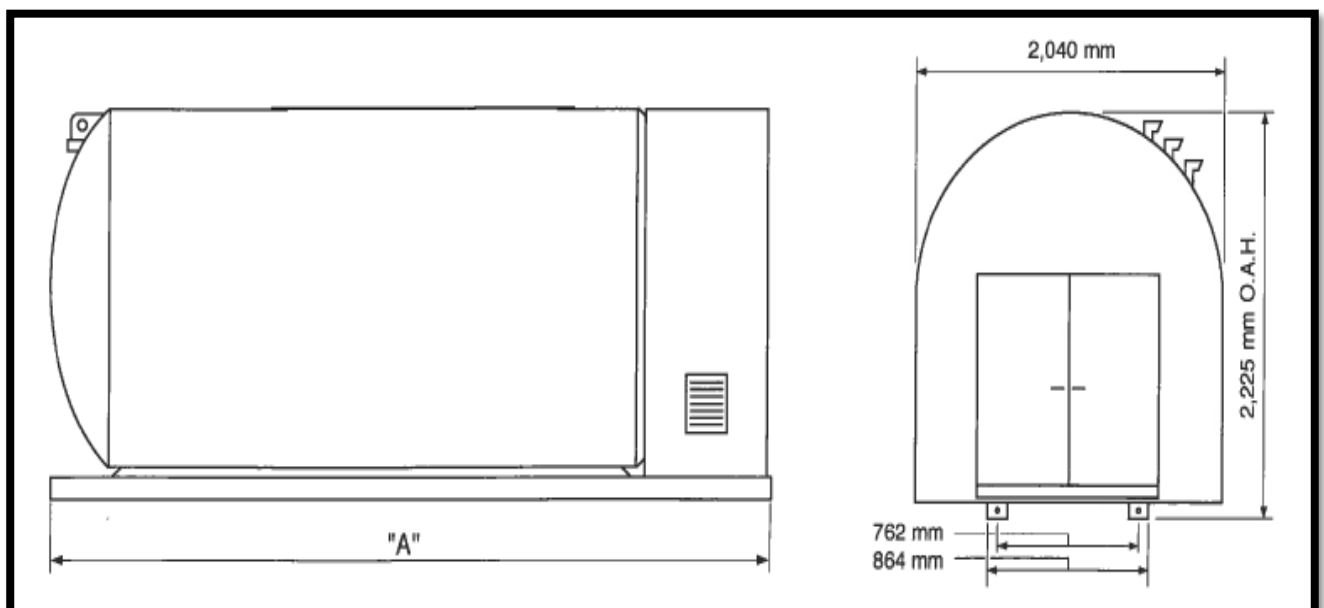

SPECIFICATION

Description	Unit	MTU 1600	MTU 2800
Dimension – Length (A) *As per drawing above	milimeter	4013	5994.4
Design Code		ADM	ADM
Inner Material		X2CrNiN 18-10 (1.4311) DIN 17440	X2CrNiN 18-10 (1.4311) DIN 17440
Maximum Allowable Working Pressure	Bar	19	19
	PSI	275	275
Capacity (Gross)	Liters	6,300	11,300
	(Net)	Liters	5,670
Weight			
Empty	Kg	4,173	5,443
Loaded : Oxygen	Kg	10,646	17,554
Nitrogen	Kg	8,756	14,016
Argon	kg	12,071	20,230

PIPING SCHEMATIC

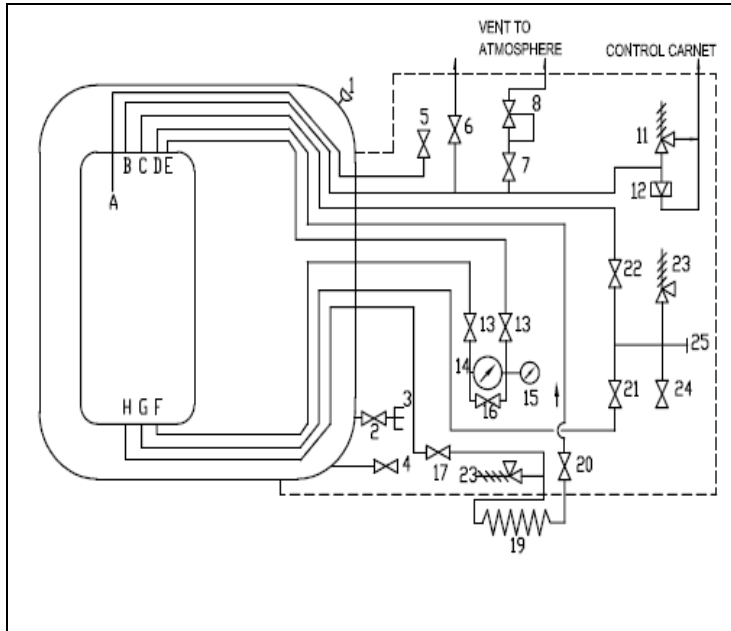

LEGEND

Tag No.	Description
1	CASING SAFETY DEVICE
2	VACUUM GAUGE TUBE ISOLATION VALVE
3	VACUUM GAUGE TUBE
4	VACUUM ISOLATION VALVE
5	FULL TRYCOCK VALVE
6	BLOWDOWN VALVE
7	ROAD RELIEF SUPPORT VALVE
8	ROAD RELIF VALVE
11	CONTAINER SAFETY VALVE
12	CONTAINER BURSTING DISC
13	CONTENTS GAUGE ISOLATION VALVE
14	CONTENTS GAUGE
15	PRESSURE GAUGE
16	CONTENTS GAUGE BYPASS VALVE
17	PRESSURE BOILING VALVE (MANUAL)
19	PRESSURE BUILDING COIL
20	COIL ISOLATION VALVE
21	LIQUID PHASE FILL/WITHDRAWAL VALVE
22	GAS PHASE FILL/WITHDRAWAL VALVE
23	BLOCK LINE RELIEF VALVE
24	HOSE DRAIN VALVE
25	FILL CONNECTION

Item	Description
A	FULL TRYCORK LINE
B	SAFETY LINE
C	TOP FILL LINE
D	P.B OUTLET LINE
E	GAS INSTRUMENT LINE
F	LIQUID INSTRUMENT LINE
G	BOTTOM FILL LINE
H	P.B INLET LINE

Specification are general and subject to change without notice.

Taylor-Wharton Malaysia Sdn. Bhd. (776817-V)

Lot Nos. PT 5073, 5076 & 5077, Jln Jangur 28/43, Hicom Industrial Estate,
40400 Shah Alam, Selangor, Malaysia
Tel : +603 5191 3003 /+603 5614 2714/2713 Fax : +603 5191 1472