

easycarb™
Operation & Maintenance
Manual
EC750-HF Model

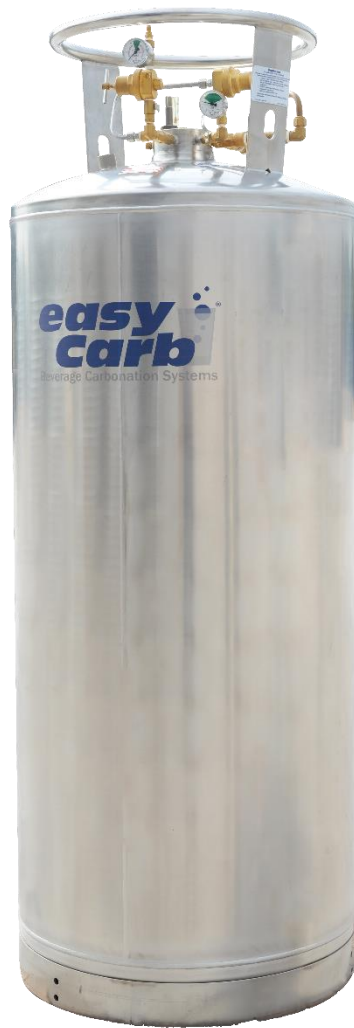

Taylor-Wharton
Since 1742

TABLE OF CONTENTS

CARBON DIOXIDE CONTAINER SAFETY.....	2
FREIGHT DAMAGE PRECAUTIONS.....	2
GENERAL INFORMATION.....	2
SPECIFICATION.....	3
INSTALLATION INSTRUCTIONS.....	4
Planning the Installation.....	4
Cylinder Handling.....	5
Installation Procedure.....	5
Leak Checking the Installation.....	7
Supply Line Installation.....	7
FILLING THE CONTAINER.....	8
MAINTENANCE.....	9
Parts Cleaning.....	9
Leak Testing.....	9
Relief Valves.....	9
Supply Line Regulator.....	10
Pressure Control Circuit.....	10
Checking Container Performance.....	10
Full View Content Gauge.....	11
Replacing the Full View Gauge.....	11
Content Gauge Installation.....	11
TROUBLESHOOTING.....	13
REPLACEMENT PARTS.....	14
Fill Box Identification.....	16
Optional Fill Box Identification.....	17
RETRO KITS for VENTED-FILL SYSTEM.....	18

CARBON DIOXIDE SAFETY PRECAUTIONS

Keep Equipment area Well Ventilated. Carbon Dioxide can cause asphyxiation by displacing oxygen needed for breathing, resulting in dizziness, unconsciousness, or death. Carbon dioxide cannot be detected by the human senses and will be inhaled like air. If adequate ventilation is not provided, the gas may displace normal air without warning that a life-threatening atmosphere is developing. Store and use carbondioxide containers only in well ventilated areas.

Extreme cold can Injure Eyes and Skin. If released to atmosphere, liquid carbon dioxide will turn to carbon dioxide snow or dry ice. Accidental contact of carbon dioxide snow or cold gas with the skin or eyes may cause severe frostbite. If you are accidentally exposed to cold snow or gas, consult a physician at once. Warm affected areas with water that is near body temperature as a first aid measure.

For additional information on carbon dioxide, ask your supplier for a Material Safety Data Sheet on this gas. Material Safety Data Sheets contain complete hazard and first aid information for the product they cover. For more information on the principles of operation and safe practices for carbon dioxide equipment refers to the Compressed Gas Association publication G-6 available from the Compressed Gas Association Inc. 1235 Jefferson Davis Highway, Arlington, VA 22202.

FREIGHT DAMAGE PRECAUTIONS

FREIGHT DAMAGE CLAIMS ARE YOUR RESPONSIBILITY. Liquid containers are delivered to your carrier from Taylor-Wharton's dock in new condition. When you receive our product, you may expect it to be in that same condition. For your own protection, take time to visually inspect each shipment in the presence of the carrier's agent before you accept delivery. If any damage is observed, make an appropriate notation on the freight bill. Then, ask the driver to sign the notation before you receive the equipment. You should decline to accept containers that show damage, which might affect serviceability.

GENERAL INFORMATION

The easy**carb**[™] High Flow system that meet the demands of high volume customers. This system offer the capacity and flow rates necessary for hih volume users such as stadiums, brew pups, cineplexes and microbreweries. This easy**carb**[™] consists of a vacuum-insulated liquefied gas container, and its associated plumbing. The system is designed for permanent installation as a source of gaseous carbon dioxide for soft drink carbonation. The easy**carb**[™] unit is manufactured to the ASME pressure vessel code. The easy**carb**[™] container is filled from an outside fill station without interrupting the flow of gaseous carbon dioxide to the points of use. Two lines are permanently attached between the easy**carb**[™] and a lockable fill box outside the building. One line is used to transfer liquid to the system from a distribution vehicle, the other conducts gas vented by safety devices to the outside of the building. The fill box station must be located for easy access by the distribution vehicle. Filling is accomplished by connecting a delivery unit to the fill port in this box. Liquid CO₂ is then transferred by pressure differential. The easy**carb**[™] operates without the need for constant attention. Personnel working at the use site may need to call their distributor to make occasional output pressure

regulator adjustments, but the other valves and controls on top of the container are normally operated only when it is necessary to turn off the gas flow for maintenance, or if the system is damaged by mishap.

The **easycarb™** High Flow tank includes an internal vaporizer coil and external plumbing configuration that combines to maintain adequate CO₂ gas supply rates. When CO₂ gas is needed, the liquid CO₂ is drawn from the inner tank and converted to gas. An adjustable line regulator supplies gas to the end use point at the desired pressure. The gas use or “final line” regulator is normally set between 90 and 115 psi. The **easycarb™** High Flow is a self-contained gas supply system capable of providing gas at maximum continuous flow rates of up to 15.0 lb./hr. (6.8 kg/hr.) See Specification Chart below.

The gas supply line is equipped with a check valve to prevent back flow into the **easycarb™**. Back flow could carry contaminants that could freeze in the cold plumbing parts, making the **easycarb™** inoperative.

Solid CO₂ (dry ice) will form if the pressure in the **easycarb™** is allowed to drop below 70 psig (4.8bar/483 kPa). In service, the pressure is maintained well above this value to ensure that solid CO₂ (dry ice) will not form inside the container.

easycarb™ Specifications

MODEL NO	EC750 HF
Part Number	EC75-OC01
	EC75-OC03
Dimension	
Diameter in.(mm)	26 (660)
Height in. (mm)	70.5 (1791)
Height with legs. In. (mm)	74.0 (1874)
Weight	
Empty lbs. (kg) (Nominal)	348 (158)
Capacity, CO ₂ Saturated @125 psig (8.6 bar)	
Liquid lbs. (kg)	789 (358)
Gaseous cu.ft (cu.m) @NTP (STP)	5756 (163)
Flow Rates	
Peak Demand lb/hr (kg/hr)	40 (18.0)
Continuous lb/hr (kg/hr)	15.0 (6.8)
Minimum Usage (no venting)	
Liquid lb / day (kg /day)	3.0 (1.4)
Pressure Building System	
Standard Operating Pressure	N/A
Economizer Circuit System	
Standard Operating Pressure	140 psig (8.6 bar)
Safety Device Setting	
Primary Relief Valve	300 psig (20.7 bar)
Secondary Relief Valve	450 psig (22.8 bar)

INSTALLATION INSTRUCTIONS

Taylor Wharton's easy**carb**™ carbon dioxide system is designed to be permanently installed. The system consists of a specifically designed container that stores carbon dioxide in the liquid state, and fill connection hardware to allow refilling from outside the building in which it is installed.

Planning the Installation

Consult with your customer, and check local code restrictions, before determining a location for the unit. The container should be installed in a location away from day to day activity to minimize tampering. It should be accessible for maintenance and occasional monitoring.

Note: This container is manufactured to ASME pressure vessel specifications. It should not be used to transport liquid carbon dioxide. The easy**carb**™ is intended to be transported to the installation site empty and filled after it is installed.

The fill box should be readily accessible for CO2 deliveries 24 hours a day. A lockable fill box is part of the installation. The fill box location should be within 35-ft. (10.7m) of the delivery point, due to the limited reach of the delivery vehicle.

For safety and ASME code requirements, the length of the fill line and vent lines from the fill box to the easy**carb**™ must not exceed 20-ft. (6m) in length. Consult Taylor-Wharton for technical assistance when installing longer lines to avoid problems.

A stainless steel surface mounted fill box is most commonly used as it minimizes modifications to the building and installation time. However, flush mounted fill boxes are available.

Plan the routing of fill and vent lines. These should be in an area well protected from accidental damage. If you can't conceal the lines, mount them to the interior walls, or secure them to overhead structural members as required by many local codes. Avoid hot areas if possible. Do not route easy**carb**™ lines near steam or hot water lines. For local regulations that require the cylinder to be elevated from the floor, we offer a platform base. If the platform base is used to elevate the cylinder; the cylinder must be anchored to a wall by its handling ring. Part numbers of the platform base and wall anchor can be found in the Replacement Parts List. It is recommended that appropriate local code approvals be reviewed prior to scheduling the installation.

Bolting a Tank (with 6" legs) to the Floor

Place the tank in its position and mark three floor-anchor bolts through the holes in the bottom of the legs. Move the tank.

Drill holes with a masonry bit having the same diameter as the anchor. Make sure the hole depth exceeds the minimum embedment of the anchor.

Assemble each anchor with a nut and washer so the top of the nut is flush with the bolt. Drive each anchor into a floor hole until the nut is against the surface of the floor. Expand the anchor by tightening the nuts 3-5 turns until firmly tight. Remove and save the nuts and washers.

Move the tank back into position being careful that the hole in the bottom of each leg is over an anchor bolt. Place a washer and nut onto each bolt and tighten.

EasyCARB Flow Diagram

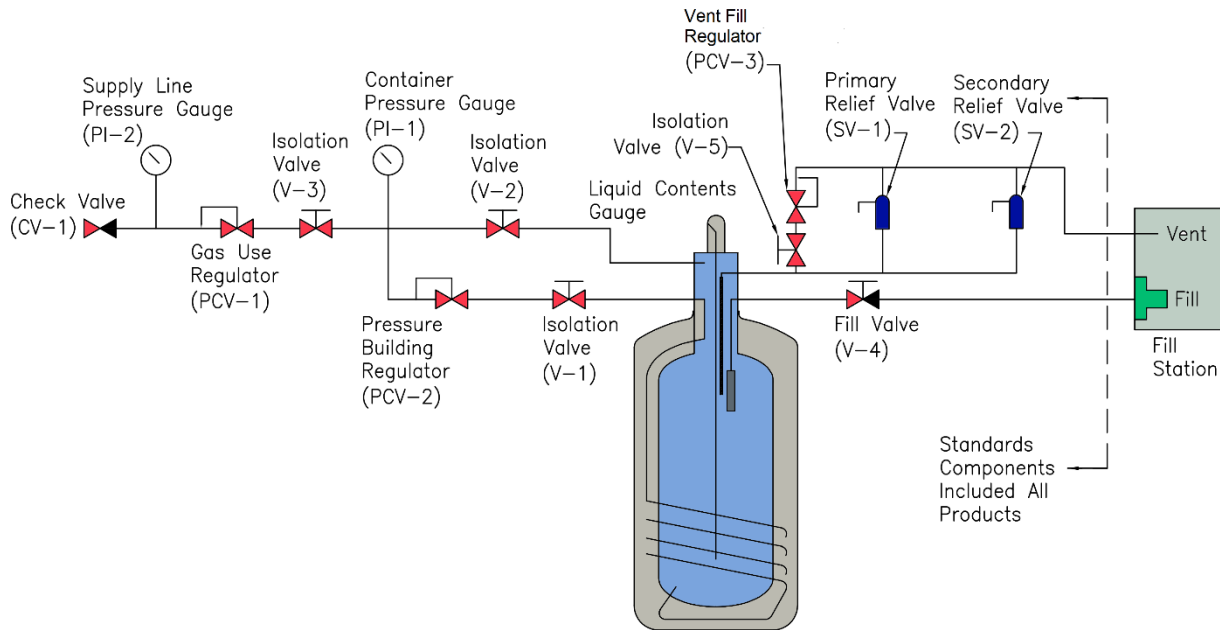

Cylinder Handling

The easycarb™ cylinder can weigh upwards of 348 lb. (158 kg), but can easily be moved by using a properly designed hand truck. A special Harper cylinder truck (Model ULG 650A) is recommended. The container can also be lifted and moved with a crane or hoist by attaching a sling to the holes, provided in the ring supports on the top of the cylinder. Do not attach lift hooks to ring. Except for minor tipping on the hand truck, the container must be kept upright at all times, and should not be moved or transported full.

CAUTION: If lifting by crane or hoist, insert hooks in both lifting lug openings on the cylinder ring. Failure to do so could result in container damage or personal injury.

CAUTION: If the container is installed in an elevated location, it must be on a well constructed platform that will support more than 975 lb. (422 kg.) When installed this way, the easycarb™ must be anchored to the wall from a point on the top of the container.

Note: Nut and ferrule for vent line and liquid connection are attached to the plumbing to prevent loss during shipment.

Installation Procedure

See page 12 for Component Identification.

1. Determine the location for the fill box on the outside wall.

SPECIAL NOTICE

Be sure and take the height of the fill box into consideration. Do not install box at face height (approx. 5 ½ ft./1.7 m). This can be dangerous during

delivery. The suggested height of mounting is approx. 3 to 4 ft. (.9 to 1.2m) above the ground.

WARNING:

Be sure there are no hidden utility lines in the location selected for mounting. Consult the building plans, or make a test opening to confirm the wall is clear of hidden hazards before drilling.

2. Measure the distance from the container to location where the fill box will be mounted to determine the length of fill and vent line material required. Be careful to allow for all routing and for thickness of the outside wall. Avoid sharp bends that may restrict liquid or gas flow.
3. Fabricate two lengths of ½ in. (12.7 mm) ODT copper or ½ in. (12.7 mm) I. D. nylon tubing.
4. Drill a small pilot hole through the outer wall surface first to confirm that there are no utility lines in the location selected, then enlarge the opening to a 2 ½ in. (64 mm) opening.
5. The fill box contains copper tube sections long enough to pass through the wall. The fill section is already coupled but you must attach the vent section to the bracket beneath the fill coupling using the strap clamp and screws provided.

Fill Station

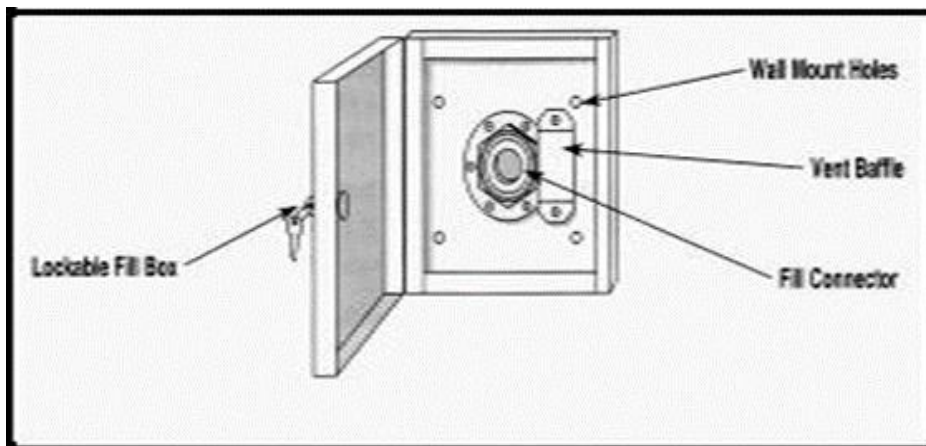

6. Pass the fill line through the wall, and mark for cutting to length. Pull the fill box back off the wall. Cut fill line to length, then cut vent line to same length, and secure with screw to bracket in back of fill box.
7. After cutting the fill box tube sections to length, install the box. Level the box, then mark four wall anchor holes and drill; secure with appropriate anchoring hardware. Weather seal between the box and the building exterior is recommended.
8. Attach the two 90° elbow compression unions to the tubing ends coming through the wall and direct them toward the fill/vent lines.
9. Carefully unload the easycarb™ tank and move it to its permanent position. It is recommended that you securely anchor the top of the container to the wall or building structure with a suitable bracket that clamps the top handling ring.

10. Route and mount both lines using ½ in. (12.7 mm) O.D. lines inside the building, until they reach the easycarb™ tank. Be sure to comply with all local building codes.
11. Cut the vent line to final length and connect it to the elbow fitting on the vent tube leading to the outside box.

WARNING:

Be careful to properly connect the vent and fill lines to the box. If the vent line is accidentally connected to the fill connection, the container relief device may be blocked, which will create a dangerous pressure build-up in the lines or the container.

12. Go to the container end of the vent line and test the line before attaching to the container by blowing through the line to confirm that is unrestricted.
13. Cut fill line to final length, couple it to the remaining fill box elbow, then connect it to the LIQUID connection on the easycarb™.
14. Apply the easycarb™ decal to the front of the container and post carbon dioxide storage identification in the general area as required by local code.

Leak Checking the Installation

Open the LIQUID valve and close the USE valve. Pressurize the system to 150 psig (10 bar/1034 kPa) with gaseous CO₂ through the fill connection. Leak test all joints using only approved leak test solutions. Follow the manufacturer's recommendations. Snoop Liquid Leak Detector is one approved solution; it is available from: Nupro Co. 4800 E. 345th St. Willoughby, Ohio 44094. Leak test all connections.

If leaks are found, isolate the leaking plumbing from the tank pressure so all pressure may be released from the area under repair.

WARNING:

In case of any downstream leaks to the point of use, close the USE Valve. Closing this valve will stop the flow of gaseous CO₂ to the Supply Line Regulator and downstream piping so that repairs can be made to any leaks.

Note: Liquid connection fitting must be assembled to liquid line using pipe thread sealant, such as teflon tape, prior to attaching the liquid line connection.

Note: After completing the tank installation, fill out the easycarb™ Warranty Card and return to Taylor-Wharton.

Supply Line Installation

1. Fill the easycarb™ using the filling procedure on page 8.
2. Install a gas supply line from the Supply Line connector, on the easycarb™ to the use point and finger tighten.
3. Open the gas USE valve and adjust the outlet regulator – normally to 90 psig (6.2 bar/621 kPa).
4. Tighten the supply line fittings at the use point.

FILLING THE CONTAINER

Schedule delivery before the container contents drop below ¼ full. This will improve the filling characteristics as well as the gas withdrawal capabilities.

Note:

During first fill the easycarb™ will be warm and pressure may equalize before tank is full. If this occurs, shut off liquid on fill gun and vent pressure in easycarb™ down to 125 psig (8.6 bar/862 kPa) through fill gun. Repeat if necessary. If you are not sure if the easycarb™ is full simply check liquid contents gauge on the easycarb™ before venting.

1. Inspect the easycarb™ for proper vent, supply and fill line installation before attempting to fill the container.
2. Check supply container valves to ensure they are open.
3. Check the pressure and contents of the supply container(s).
4. Extend the fill hose to the fill box.
5. Inspect all connections for cleanliness. Any moisture that is present can freeze during liquid transfer. Use a clean, dry cloth to wipe connections if necessary.
6. Open liquid ball valve and purge the fill gun vent until liquid appears. After this is complete shut the liquid ball valve. Next shut the vent ball valve.
7. Connect the fill gun to the fill connector and read the customer tank pressure to ensure a positive differential.
8. Open the liquid valve on the fill gun to begin the fill. Never leave the Fill Gun unattended during the fill.
9. When the pressure indicated on the fill gun begins to rise sharply, terminate the fill.
10. Close the Liquid Fill valve, and disconnect the fill gun from the fill station. Open the fill gun Vent valve to relieve trapped pressure.
11. When filling a tank equipped with the option, make sure the isolation valve in the Vent Fill circuit is open.
12. Filling thru Vent Fill: Open the liquid delivery valve to allow liquid CO₂ to flow into the tank. The Vent Fill valve will open when the tank pressure reaches approximately 200 psi. At that point a pressure relief venting noise will be heard from the vent fitting below the fill connection in the fill box. Continue filling.
13. When the venting stops the tank is full. Disconnect the fill hose from hose from the fill station.

WARNING:

Delivery systems with operating pressures greater than 300 psig (20.7bar/2068 kPa) may over-pressurize the easycarb™ if not used properly. Do not allow the pressure, as displayed on the fill gun, to exceed 300 PSI during the fill.

MAINTENANCE

For specific maintenance procedures refer to the applicable paragraph that follows, and to the replacement parts list.

WARNING:

Isolate components and slowly de-pressurize the plumbing to be repaired before attempting repairs. The sudden release of pressure could cause personal injury. Observe safety precautions to prevent dangerous accumulation of gas. Safety devices and liquid level contents gauge cannot be isolated therefore all liquid must be removed and all pressure in vessel must be relieved before attempting to repair them.

CAUTION: *Carbon dioxide may form into the solid phase (dry ice) if the pressure over the liquid is allowed to drop below 70 psig (4.8 bar/483 kPa). Pressure in the container must be maintained above this value to ensure solid CO₂ will not form inside the container. Before performing maintenance, the contents of the easycarb™ must be transferred to another container so that pressure can be released.*

CAUTION: *If the contents have solidified, the dry ice in the container may be thawed by pressurizing the container to 280 psig (19.3 bar/1931 kPa) with carbon dioxide gas from an external source. This may be accomplished by connecting a high-pressure cylinder with regulator to the fill line of the easycarb™ (adapters will be required). Several days at this pressure may be required to thaw the container. For more information, consult CGA pamphlet G-6.7, "Safe Handling of Liquid Carbon Dioxide Containers that have Lost Pressure."*

Parts Cleaning

Before installing, be sure to properly clean any replacement parts that are not pack-aged and marked for oxygen service. Keep all parts clean during installation to prevent contamination of the carbon dioxide. For more information on cleaning, consult the compressed Gas Association (CGA) pamphlet G-4.1, "Cleaning for Oxygen Service" or equivalent industrial cleaning specifications.

Leak Testing

After every repair, pressurize the container to about 280 psig (19.3 bar/1931 kPa) through the Liquid connection with a regulated source of clean dry carbon dioxide gas. Use only approved leak test solutions and follow the manufacturer's recommendations. "Snoop" Liquid Leak Detector is one approved solution, it is available from: Nupro Co. 4800 E. 345th St. Willoughby, Ohio 44094. If leaks are detected, isolate container pressure and relieve pressure on the lines before repairing, then retest when repairs are completed.

Relief Valves¹

Replace the relief valve when it fails to maintain its setting or when it leaks at pressures below

its setting. If the relief valve functions properly, but operates too frequently, it may be an indication that the insulation space vacuum has deteriorated. Follow the instructions in the Evaporation Rate Test Procedure to check the condition of the vacuum. Never try to repair relief valves.

¹ See warning on removing contents before releasing container pressure at the beginning of the Maintenance Section.

Supply Line Regulator

The supply line regulator reduces the pressure of the carbon dioxide gas from the easycarb™ container to the level required by the carbonation system. It provides a constant supply pressure. To adjust the supply line regulator:

1. Loosen the adjustment screw retaining nut.
2. Adjust the regulator (tee handle) on the Supply Line Pressure Gauge.
3. Tighten the adjustment screw retaining nut.

Pressure Control Circuit

The pressure control circuit (Economizer) maintains optimal operating pressure and conserves gas for efficient system performance.

Checking Container Performance

The easycarb™ is basically two containers, one within the other. The space between the containers acts as a thermal barrier because of high technology insulation and a vacuum. Each serves a very important part in the useful life of the container. The insulation is very effective in preventing radiated heat from entering the inner container; the vacuum prevents heat convection or conduction from reaching the liquid contents. When the vacuum in the insulation space is no longer effective, the following symptoms may appear:

- When the container is filled with liquid, the outer casing will be much colder than normal.
- Frost, indicating the liquid level, may be visible on the outer casing of the container.
- The container may appear to “sweat” if the air surrounding the container is hot and humid.
- The relief valve will open continuously until the container empties prematurely.

Note: See the TROUBLE-SHOOTING Section for more detailed symptoms.

Normal Evaporation Rate (NER) Testing. If a loss of vacuum integrity is suspected, the container’s Normal Evaporation Rate should be checked. Take the container out of service and perform the following test:

The container must be in a well-ventilated area where the temperature is approximately 70°F (21°C.)

1. Fill the container until it contains at least 125 lbs. (57 kg).
2. Allow the container to stabilize with all valves closed until it vents through the relief valve. Weigh the container. Record the weight, time and date.
3. Reweigh after the container is allowed to vent for 24 hours. Record the weight, time and date.
4. If the weight of the carbon dioxide lost in 24 hours is greater than 8 lbs. (3.6 kg), the container may have lost its vacuum.

5. If the above test is inconclusive, reweigh again after 48 hours. The test is most effective if container is not moved during this period.
6. If the total amount of carbon dioxide lost in the 48 hour test exceeds 20 lb. (9.0 kg), the container may be considered defective.

Full View Contents Gauge

The content of these containers is measured with the Full View Contents Gauge. The device consists of the gauge body and snap on level indicator. When the gauge is assembled, the indicator is magnetically coupled to the top of a float rod that moves up or down with the changing level of liquid in the container.

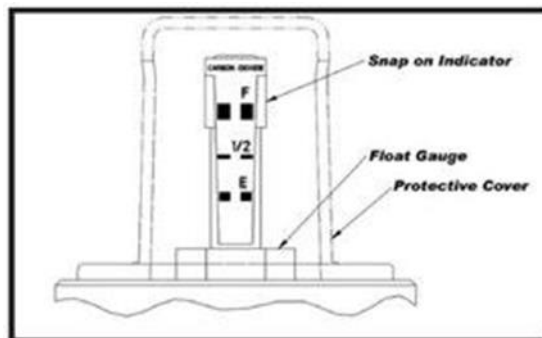

Replacing the Full View Contents Gauge

The easycarb™ must be empty of liquid carbon dioxide before attempting to remove the contents gauge, or the contents will solidify. Remove all pressure from container and remove the clear protective cover by removing three (3) screws at its base. Un-screw gauge body using a wrench on the hex fitting at the base of indicator tube.

Lift the entire gauge assembly free of the container. The gauge assembly is long and may be very cold. Gloves should be used to protect your skin.

Contents Gauge Installation.

Before installing a new or repaired gauge, inspect the gasket, if any damage is apparent replace.

CAUTION: When installing the gauge assembly, care must be taken to ensure that the float rod is inserted through the "guide ring" located on the fill line inside the container. If the gauge does not engage this ring, the contents indication will be inaccurate, or the gauge may be damaged in use.

1. When inserting the gauge assembly, lower the float rod through the gauge opening until about 8 in. (203 mm) of the float rod remains above the container.
2. Grasp the upper portion of the float rod with two fingers so that the assembly hangs free and "plumb".
3. Lower the assembly about 4 in. (102 mm) slowly and try to keep the rod in the center of the threaded entrance hole as you do. If you are careful during this portion of insertion, you will drop the float rod straight through the guide ring inside the container.

4. To confirm that the rod is correctly positioned in the container, stop where you can still grasp the top of the rod and try to swing the lower end from side to side.
5. When the rod is engaged in the guide ring, the rod will be restricted to lower end movement of about ½ in. (12.7 mm); if you can feel greater movement, withdraw the rod to the point where its top is 8 in. (203 mm) above the gauge opening and try again.
6. When you are satisfied that the gauge rod is correctly installed, lower the assembly the rest of the way into the container until the top portion threads can be engaged.
7. Screw the gauge in place and hand torque to about 20 ft. lbf (2.8 kgf m). Leak check the connection of gauge body to the flange, and replace the protective cover.

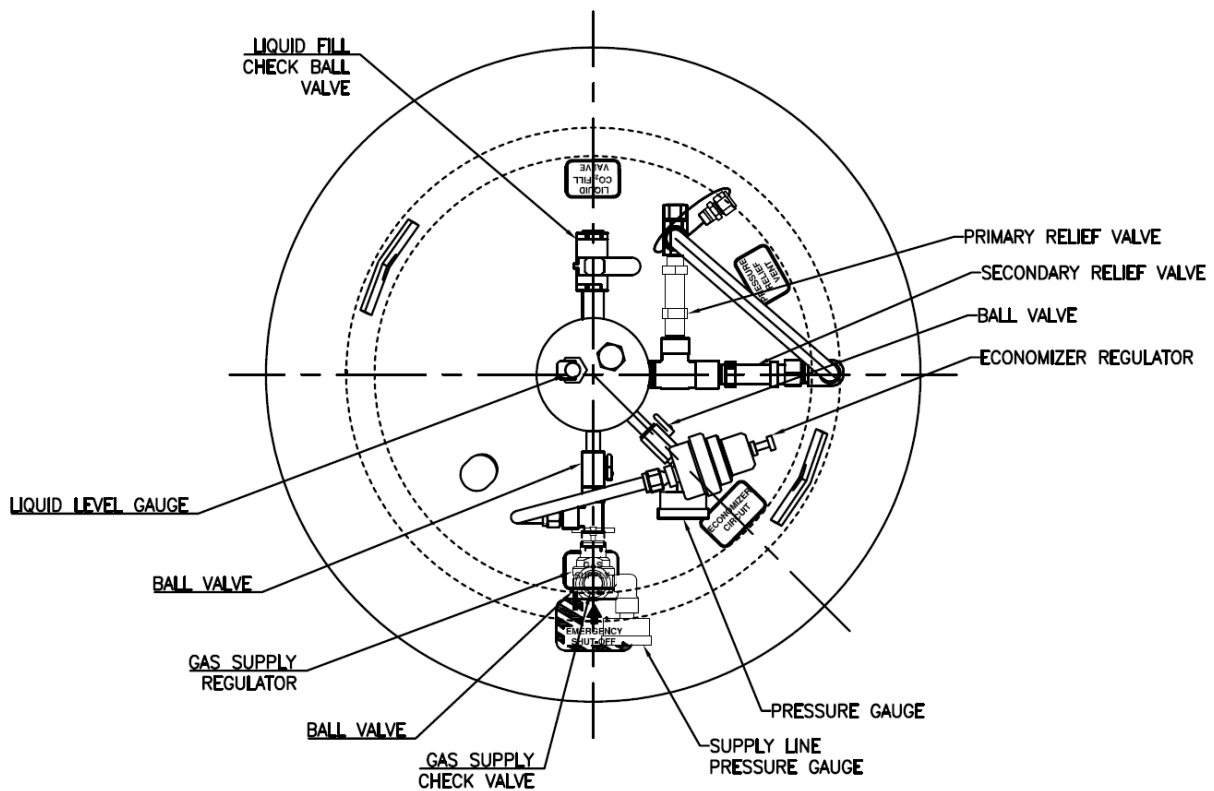

COMPONENT I.D.

TROUBLESHOOTING

Symptom	Possible Cause	Corrective Action
Frost on bottom of easycarb™	<ol style="list-style-type: none"> 1. Frost may appear during periods of high use- this is normal. 2. Leak in beverage system. 	<ol style="list-style-type: none"> 1. None required. 2. Repair leak.
Frost on easycarb™ and container is noticeably cold over entire outer surface.	Loss of container vacuum.	See "Checking Container Performance" in maintenance section.
Low supply pressure. Container level gauge shows zero.	Out of CO ₂	Call supplier for filling.
Low supply pressure - easycarb™ pressure is okay.	<ol style="list-style-type: none"> 1. Supply line regulator inncorretly set. 2. Supply line leaking. 3. USE valve on tank closed. 4. Leak in beverage system. 5. Restriction in gas supply line. 	<ol style="list-style-type: none"> 1. Set to 90 psig (6.2 bar/ 621 kPa) or required supply pressure. 2. Repair leak. 3. Open Valve. 4. Repair leak. 5. Close USE valve and open beverage line at a convenient point to isolate restriction.
Costant low tank pressure (Gauge below 150 psi)	Economizer regulator set too low or stuck open.	Readjust economizer regulator setting pressure.
Constant high tank pressure (above 200 psi).	Economizer regulator set too high or stuck closed.	Readjust economizer regulator setting pressure.
High carbon dioxide consumption.	CO ₂ leak from tank plumbing, CO ₂ fill box, gas lines and/or beverage or other use-point equipment.	Evacuate and ventilate the room. Locate and correct leak if possible. Call service agent.
easycarb™ won't fill.	<ol style="list-style-type: none"> 1. LIQUID valve closed. 2. Tank already full. 3. Delivery vehicle pressure too low. 	<ol style="list-style-type: none"> 1. Open valve. Handle should be parallel with fill line. 2. None required. 3. Determine cause and restore pressure.
Internal easycarb™ Pressure too high – Container won't fill.	<ol style="list-style-type: none"> 1. Customer usage too low. 2. Customer tank insulation system failure. 	<ol style="list-style-type: none"> 1. Vent customer tank through fill gun to 125 psig (8.6 bar/862 kPa). 2. See "Checking Container Performance" in Maintenance Section.
easycarb™ venting – pressure 270 psig (18.6 bar/1862 kPa).	Relief valve stuck open.	Replace relief valve.
easycarb™ venting – pressure 300 psig (20.7 bar/2068 kPa).	<ol style="list-style-type: none"> 1. Normal relief valve operation. 2. Loss of vacuum. 	<ol style="list-style-type: none"> 1. None required. 2. Perform NER test.

REPLACEMENT PARTS

The following replacement parts list is keyed to the accompanying illustrations for parts identification purposes. All replacement parts should be purchased from Taylor-Wharton. When placing orders, please use the nomenclature and part numbers in this section and send written orders to:

Taylor-Wharton
PT 5073,5076&5077 Jln Jangur 28/43,
HICOM Industrial Estate,
40400 Shah Alam, Selangor,
Malaysia.

FAX: 60-3-51911472
Phone: 60-3-51913003

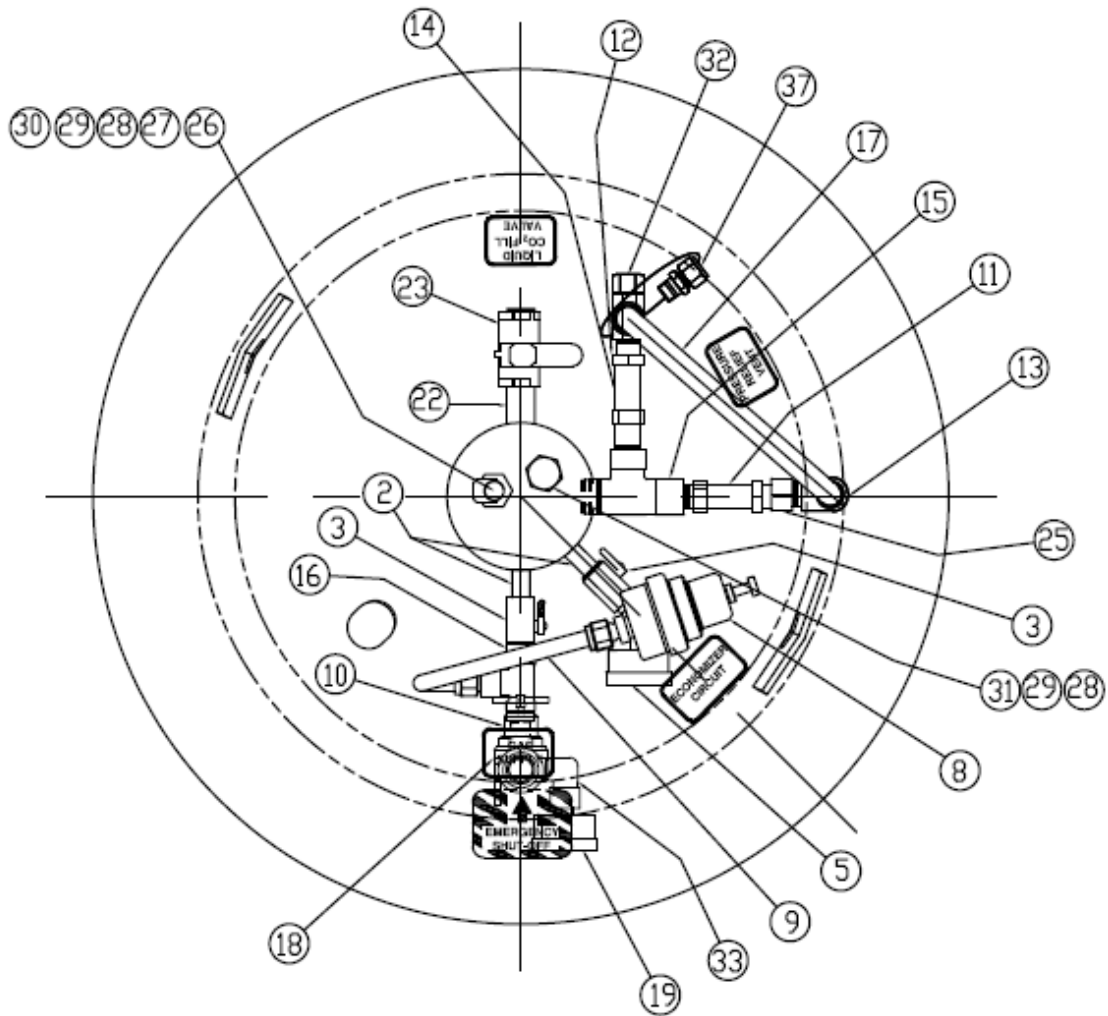

NO	QTY	PART NUMBER	DESCRIPTIONS
2	2	1750-9C26	NIPPLE, 2' LG X 1/4" PS X 1/4" NPT, STN STL
3	3	6919-9085	BALL VALVE, 1/4" NPT X 1/4" MNPT, BRASS
4	3	6816-0100	MALE BRANCH TEE, 1/4" X 1/4" X 1/4" NPT, BRASS
5	1	7702-6208	PRESSURE GAUGE, 1/4" BT, 0-100 PSIG, VDA
6	2	7395-4780	MALE CONNECTOR, 3/8" OBT X 1/4" MNPT, S/S
8	1	8816-1066	ECONOMIZER REGULATOR, PB, 140 PSIG, 1/4" NPT
9	1	HF75-9C08	TUBE, ECONOMIZER, 3/75 O.D X .035 WALL SEAMLESS, S/S
10	2	4502-7025	MALE ADAPTOR, 1/4" MNPT X 1/4" MNPT, BRASS
11	1	6919-9089	RELIEF VALVE, 1/2" NPT, 338 PSIG
12	1	6913-9226	PIPE-AWAY FOR RELIEF VALVE, 1/2" NPT, BRASS, 0-29434-S
13	1	6814-9017	MALE ELBOW, 1/2" OBT X 1/2" NPT, BRASS
14	1	6913-9084	ASME SAFETY RELIEF VALVE, 1/2" NPT, 300 PSIG, C-1043R00
15	1	6816-9211	STREET TEE, 1/2" FNPT X 1/2" FNPT X 1/2" MNPT, BRASS, PARKER
16	1	4350-6420	FEMALE TEE, 1/4" NPT, BRASS
17	1	CC00-9C18	SAFETY VENT TUBE, 1/2" O.D, COPPER
18	1	8816-1040	REGULATOR, 90 PSIG, 1/4" NPT
19	1	7702-6209	PRESSURE GAUGE, 0-200 PSIG, 1/4" NPT, VDKA
20	2	6816-9927	STREET TEE, 1/4" NPT, BRASS
21	1	6916-9352	CHECK VALVE, 1/4" NPT, BRASS
22	1	BC04-9C28	HALF NIPPLE, .075 SCH40 PIPE X 250 LG
23	1	6916-7123	CHECK BALL VALVE, 3/8" NPT
25	1	6913-9225	PIPE-AWAY FOR RELIEF VALVE, 1/2" NPT, BRASS
26	1	BC04-9C65	GAUGE, LIQUID LEVEL
27	1	BC04-9C75	INDICATOR SCALE
28	2	7701-0080	GASKET, GLASS FILLED TEFLON
29	2	7701-0080	GASKET, COPPER, 1" O.D X 3/4" I.D X .028" THK
30	1	GL45-9C97	FLUID T ROD, ALUMINUM
31	1	6010-2180	HOLLOW HEX PLUG, 3/4"-16 STRAIGHT THREADS WITH O-RING
32	1	6816-0200	MALE RUN TEE, 1/2" OBT X 1/2" OBT X 1/2" MNPT, BRASS
33	3	6814-3998	STREET ELBOW, 1/4", BRASS
37	1	7395-4771	CONNECTOR, MALE, 1/2" OBT X 3/8" MNPT, BRASS

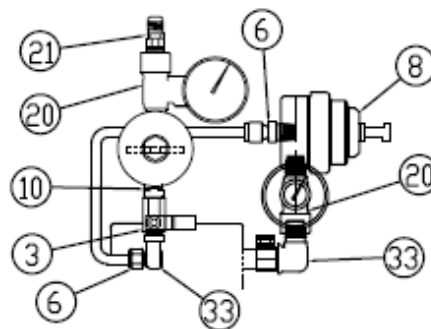

ECONOMIZER & GAS SUPPLY CIRCUIT

Fill Box Identification

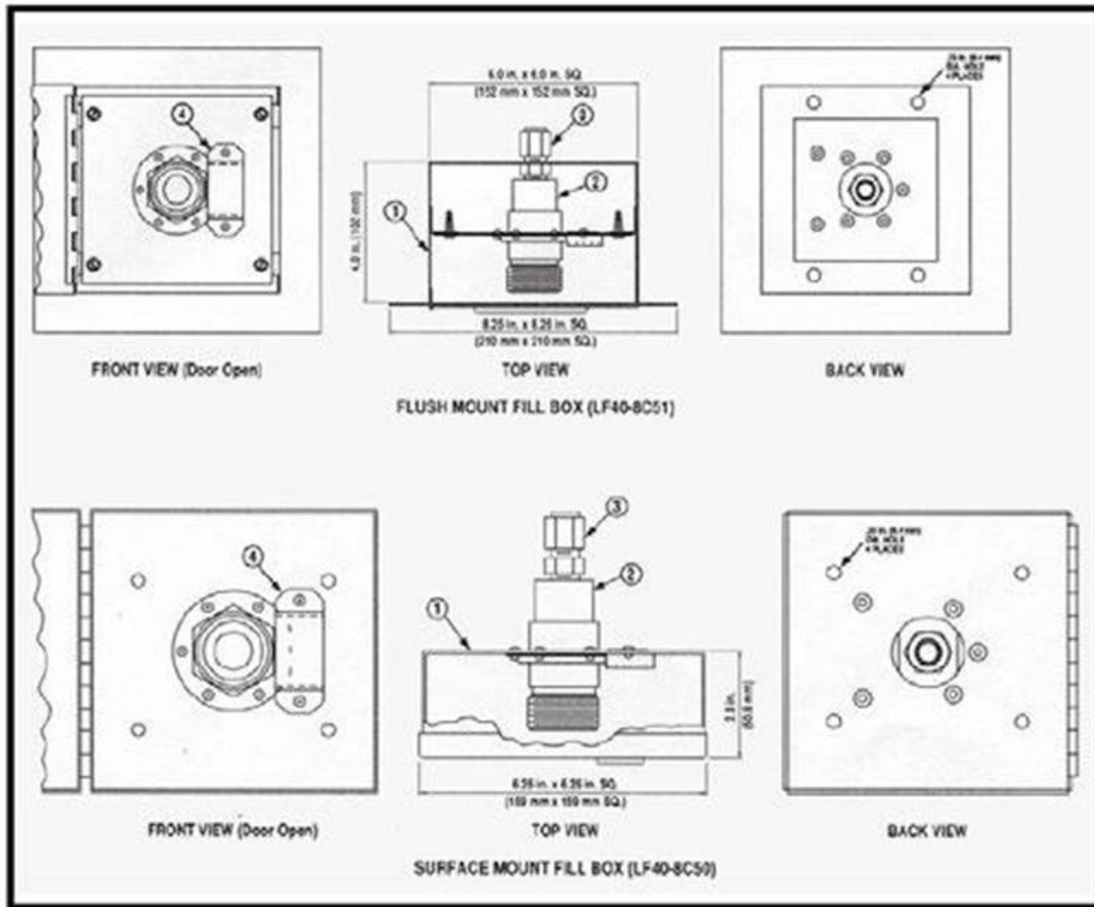

Item	Part Number	Description
1	BC04-8C26	Fill Box, Surface Mount
	BC04-8C35	Fill Box, Flush Mount
2	6812-9415	Brass Coupling w/mounting flange, Thread to Connect
3	45702030	Male Connector, 1/2 in. ODT x 1/2 in. NPT Brass
4	BC04-8C22	Baffle, Vent Tube
*	7854-6150	Fill Hose Assembly, 15 ft. (4.5 m)
*	7854-6155	Fill Hose Assembly, 6 ft. (1.8 m)

* Not Illustrated

Optional Fill Box Identification

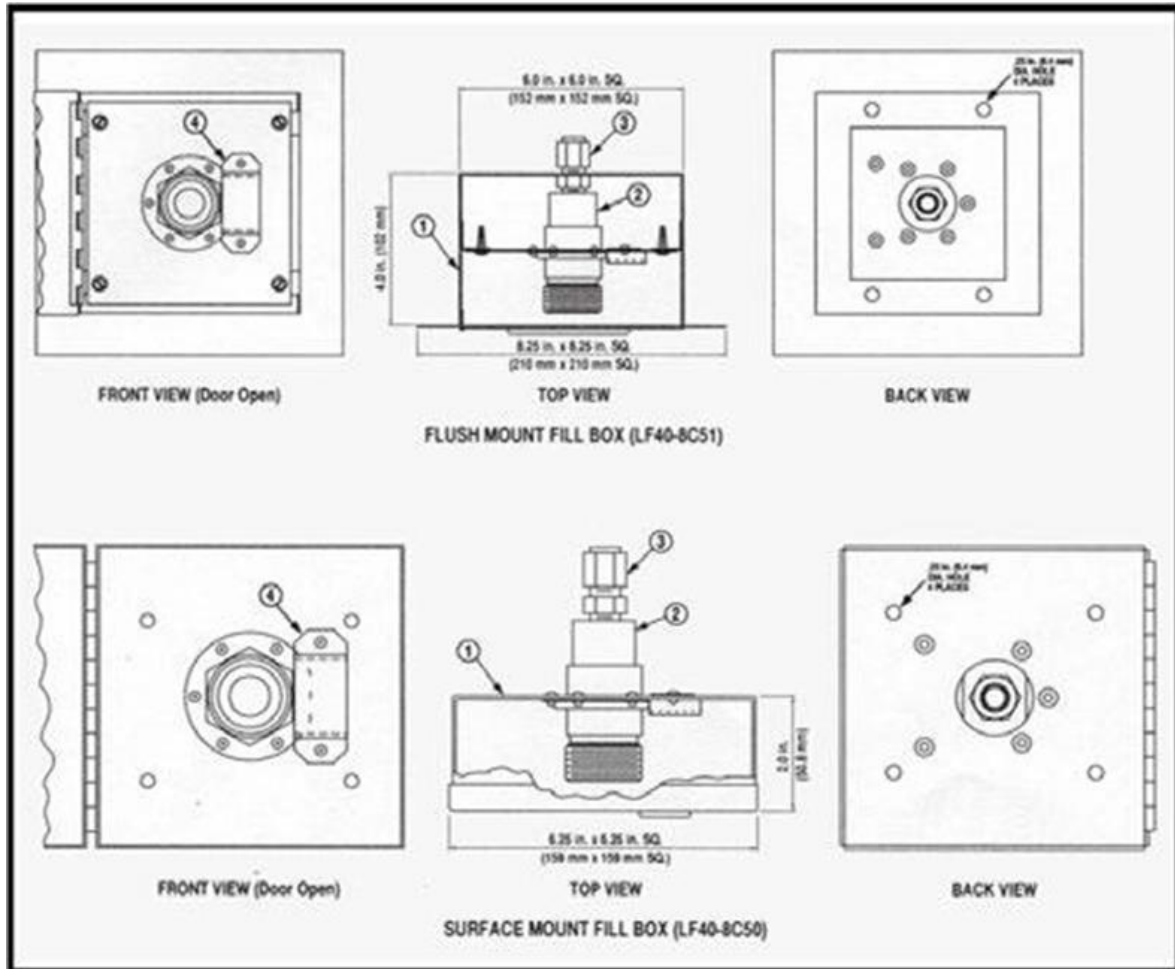

Item	Part Number	Description
1	BC04-8C26	Fill Box, Surface Mount
	BC04-8C35	Fill Box, Flush Mount
2	6812-9415	Brass Coupling w/mounting flange, Thread to Connect
3	45702030	Male Connector, 1/2 in. ODT x 1/2 in. NPT Brass
4	BC04-8C22	Baffle, Vent Tube
*	7854-6150	Fill Hose Assembly, 15 ft. (4.5 m)
*	7854-6155	Fill Hose Assembly, 6 ft. (1.8 m)

*Not Illustrated

Retro Kits for Vent-Fill System

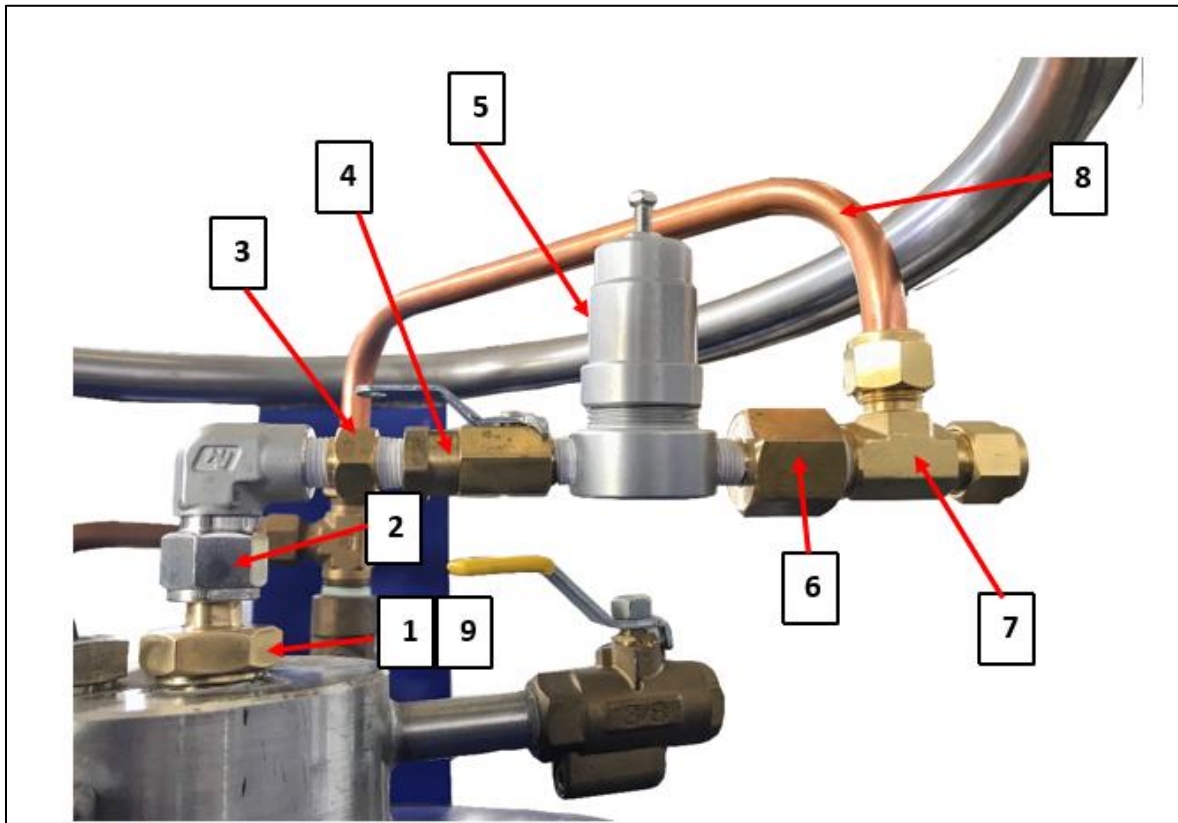

Part List of Retro Kits for Vent Fill

No.	Part No	Description	Qty	Remark
1	EC30-9C12	VENT FILL ASSEMBLY	1	EC30-9C13 for EC750 Knorr
2	4325-6422	ELBOW, ¼" FNPT X ½" ODT	1	
3	6810-8129	BUSHING, ¼" MNPT – ¼" MNPT	1	
4	6919-9085	BALL VALVE, ¼" FNPT X ¼" MNPT	1	
5	6999-9024	MASTER PNEUMATIC REGULATOR, ¼"	1	
6	6810-8130	BUSHING, ¼" MNPT-1/2" FNPT	1	
7	6816-0200	MALE RUN TEE, ½" MNPT X ½" ODT	1	
8	EC00-9C35	VENT LINE, TUBE ½" OD	1	Straight tube to be bend on site to connect directly to safety relief valve line.
9	7701-0083	GASKET, O-RING	1	
10	-	TEFLON TAPE	1	