



Taylor-Wharton
Since 1742

Instruction for Storage and Transport Containers for XL™ (LC) Series:

Trademark Model	XL™180MP	XL™193MP
Model Type per Approval	LC180M	LC193M

Trademark Model	XL™176HP	XL™208HP	XL™247HP
Model Type per Approval	LC176H	LC208H	LC247H

Do not attempt to use or maintain this unit until you read and understand these instructions. Do not permit untrained persons to use or maintain this unit. If you do not fully understand this instruction, contact your supplier for further information.

TAYLOR- WHARTON MALAYSIA SDN. BHD

Lot Nos. PT5073, 5076 & 5077
Jalan Jangur 28/43
Hicom Industrial Estate
40400 Shah Alam
Selangor Darul Ehsan, Malaysia
Fax: 00 603 5191 1472

Contents

	Page
1. Container Safety	3
2. Product Description	4
3. Specification	4
4. Handling of the Container	6
5. Operation	7
6. Component Description	7
7. Pressure Building	10
8. Withdrawal Gas from the Container	11
9. Withdrawal Liquid from the Container	11
10. Filling the Container	12
11. Repair and Maintenance	14
12. Change of Gas Service	15
13. Purge Procedure	15
14. Dual Stage Regulator	16
15. Regulator Adjustment on Container	16
16. Checking Container Performance	17
17. Checking Normal Evaporation Rate (NER Test)	17
18. Liquid Level Indicator	19
19. Replacement Instruction	20
20. Trouble Shooting Chart	26
Disclaimer	28



1. Container Safety

- **Pressure Hazard** – The containers covered by this literature contain liquefied gas under pressure up to 10 bar. Sudden release of this pressure may cause personal injury by issuing cold gas or liquid, or by expelling parts during servicing. Do not attempt any repairs on these containers until all pressure is released, and the contents have been allowed to vaporize to ensure no pressure build up can occur.
- **Extreme Cold – Cover Eyes and Exposed Skin** – Accidental contact of the skin or eyes with any cryogenic liquid or cold issuing gas may cause a freezing injury similar to frostbite. Protect your eyes and cover your skin when handling the container or transferring liquid, or in any instance where the possibility of contact with liquid, cold pipes, and cold gas may exist. Safety goggles or a face shield should be worn when withdrawing liquid or gas. Long-sleeved clothing and gloves that can be easily removed are recommended for skin protection. Cryogenic liquid is extremely cold and will be at temperatures below minus 196°C under normal atmospheric pressure.
- **Keep Equipment Well Ventilated** – Although the gases used in these containers are non-toxic and nonflammable, they can cause asphyxiation in a confined area without adequate ventilation. An atmosphere that does not contain enough oxygen for breathing can cause dizziness, unconsciousness, or even death. These gases cannot be detected by the human senses and will be inhaled normally as if they were air. Ensure there is adequate ventilation where these gases are used and store liquid containers outdoors or only in a well-ventilated area.
- **Replacement Parts Must be 'Cleaned for Oxygen service'** – Some materials, especially nonmetallic gaskets, and seal, can be a combustion hazard if used in oxygen or nitrous oxide service. Use only Taylor-Wharton recommended spare parts, and be certain parts used are properly cleaned to prevent contamination of stored product. For information on cleaning, consult the Compressed Gas Association (CGA) pamphlet G-4.1, “Cleaning for Oxygen Service” or equivalent industrial cleaning specifications.
- **Install Relief Valves in Cryogenic Liquid Lines** – When installing piping or fill hose assemblies, make certain a suitable safety relief valves are installed in each section of plumbing between shut-off valves. Trapped liquefied gas will expand as it warms and may burst hoses or piping causing damage or personal injury.

NOTE: For detail information on the handling of cryogenic liquids, refer to the Compressed Gas Association publication: P-12 “Safe Handling of Cryogenic Liquids.” Available from the Compress Gas Association, 1235 Jefferson Davis Highway, Arlington, VA 22202, USA **Please pay attention to all laws, rules, and recommendations about handling of cryogenic liquefied gases and materials, that are valid in your country.**

2. Product Description

The XL™-MP (LC-M) Series is vacuum-insulated container made of stainless steel, designed for the storage and the transportation of cryogenic liquid nitrogen, oxygen, and argon, or in case of the XL™-HP (LC-H) series, carbon dioxide. The containers are approved accordance to the European Directive for portable pressure vessels TPED (2010-35- EU, dated 03.09.2011) and may be used for transport of cryogenic liquid over public roads or for storage or delivery in many applications. The exceptional low evaporation rate makes those vessels to first class independent gas supply sources, which allow a continuous gas flow of up to 9.2 m³/ hour at 7 bars.

3. Specification

Trademark Model	XL™180MP	XL™193MP	XL™176HP
Model Type per Approval	LC180M	LC193M	LC176H
Part Number	LC180M-OC12TPED	LC193M-OC12TPED	LC176H-OC12TPED
Dimensions			
Diameter, (mm)	508	508	508
Height, (mm)	1524	1600	1524
Weight			
Empty (Nominal), (kg)	133	139	151
Gross Liquid Capacity, (L)	180	193	176
Net Liquid Capacity, (L)	169	181	165
Normal Evaporation Rate⁽²⁾ (% Capacity per Day)			
Nitrogen	1.9	1.8	2.2
Oxygen & Argon	1.2	1.1	1.4
Carbon Dioxide	-	-	0.75
Safety Device			
Pressure Relief Valve, (bar)	16	16	24
Inner Container Bursting Disc, (bar)	25	25	36

specification cont...

Trademark Model	XL™208HP	XL™247HP
Model Type per Approval	LC208H	LC247H
Part Number⁽¹⁾	LC208H-OC14TPED	LC247H-OC14TPED
		LC247H-OC15TPED
Dimensions		
Diameter, (mm)	508	660 ⁽³⁾
Height, (mm)	1650	1470
Weight		
Empty (Nominal), (kg)	164	201 ⁽⁴⁾
Gross Liquid Capacity, (L)	208	247
Net Liquid Capacity, (L)	198	240
Normal Evaporation Rate⁽²⁾ (% Capacity per Day)		
Nitrogen	1.9	2.8
Oxygen & Argon	1.2	1.7
Carbon Dioxide	0.75	1.3
Safety Device		
Pressure Relief Valve, (bar)	24	24
Inner Container Bursting Disc, (bar)	36	36

(1) H-Series cylinder with the following option:

Part Number	Designations
-OC14TPED	Round Base Caster
-OC15TPED	Square Base

(2) Vented NER based on Useable Liquid capacity. Specifications are subject to change without prior notice.

(3) Square Base Dimension: 718mm x 718mm.

(4) This weight based on the round base. The weight with square base design is approximately 10-15% heavier.

4. Handling of the Container

The XL™ (LC) Series containers are very rugged liquid cylinders. All cryogenic liquid containers have an inner container and an outer casing with a super-insulated vacuum space between them; any abuse (dents, dropping, tip-over, etc.) can affect the integrity of the container's insulation system. When moving the cylinder, the following precautions should be observed:

- Never lay the container on its side. Always ship, operate, and store the unit in a vertical or upright position.
- **The liquid cylinders should only be moved by utilizing an appropriate cylinder cart, roller base or overhead crane over smooth, level and even floor surface.**
- Do not roll a liquid cylinder by the handling ring.
- When loading or unloading the container from a truck, use a lift gate, a crane, or a parallel loading dock. Never attempt to manually lift the unit.
- To move the container over rough surfaces or to lift the container, attach an appropriate sling to the lifting points cut into the welded support posts, and use a portable lifting device that will handle the weight of the container.
- Liquid cylinders are generally not designed to be permanently mounted on a truck. Depending on the design of the fixation, the permanent transversal vibrations and resonances put a high stress on the inner vessel supports, so that Taylor-Wharton cannot keep the warranty for the vacuum. Please seek advice from Taylor-Wharton in order to look for possible solutions.



A pull handle is provided on the OD 26" (OD 660mm) outer body of the cylinder with round base caster to move the cylinder around. Those pull handle should only be used to move cylinders over flat and smooth surface.

The proper handling method is to hold the handrail ring and the pull handle on the shell with both hands at the same time when pulling the cylinder around. Do not use the handles to pull cylinders up or down inclines. Also, they should not be used to lift cylinders, with or without product in them.

The cylinder with caster wheel design is only used when frequent and short distances are required. Before utilizing this method of transportation, make sure the area over which the liquid cylinder is to be moved is flat and smooth.

Freight Damage Precautions. Any freight damage claims are your responsibility. Cryogenic liquid containers are delivered to your carrier from Taylor-Wharton's dock in new condition. When you receive our product, you may expect it to be in the same condition. For your own protection, take time to visually inspect each shipment in the presence of the carrier's agent before you accept delivery. If any damage is observed, make an appropriate notation on the freight bill. Then, ask the driver to sign the notation before you receive the equipment. You should decline to accept containers that show damage which may affect serviceability.

5. Operation

Following descriptions are most important for a proper handling of all XL™ (LC) cylinders. Components and operations will be described, which should be read in any case, before you put the vessel into operation. The components and instruments can be identified from the pictures and drawings.

The model numbers of these XL™ (LC) Series indicate their respective gross liquid capacities in liters. The cylinders can be filled liquid according to their net content. All these XL™ (LC) vessels are suitable for liquid/gaseous nitrogen, oxygen, and argon.

6. Component Description

Components XL™ (LC) Series

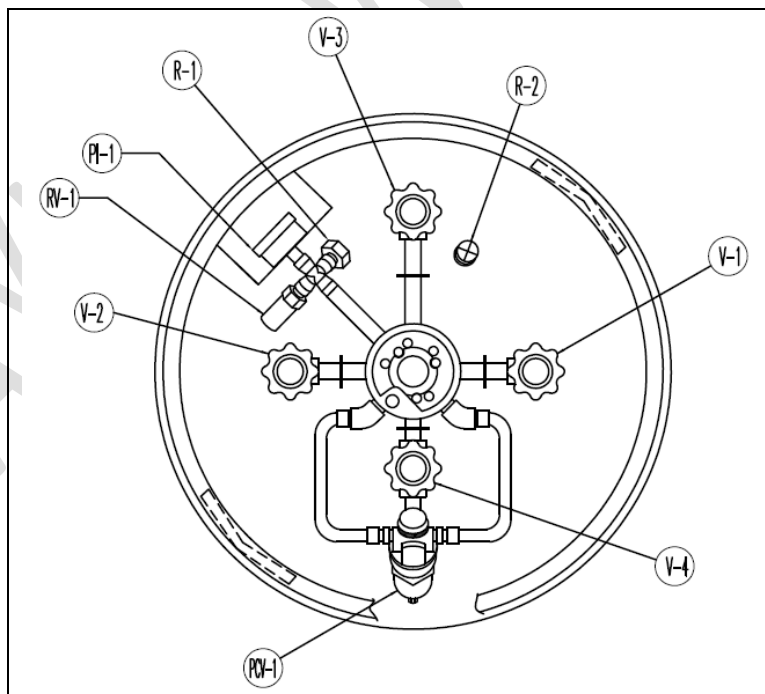

Flow Diagram XL™- MP/HP (LC-M/HP) Series

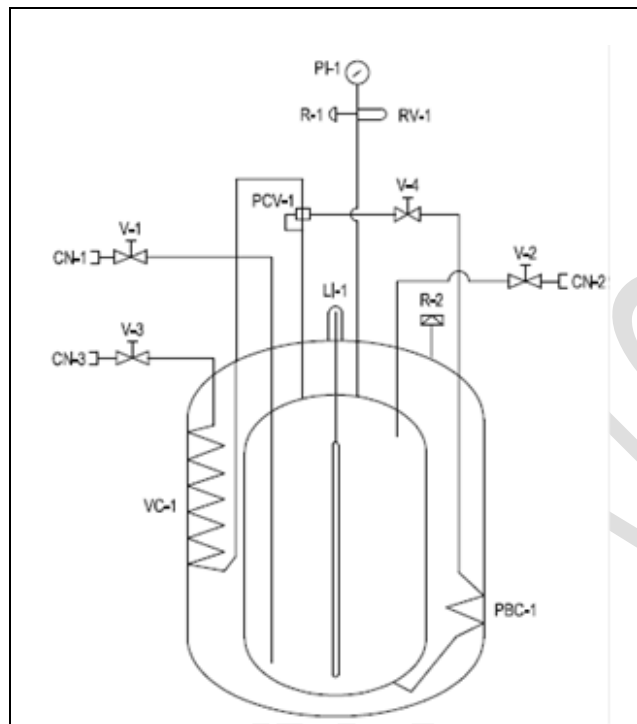

Abbreviation	Description
LI-1	Liquid Level Indicator
PI-1	Pressure Gauge
PBC-1	Pressure Building Coil
PCV-1	Dual Pressure Building/Economizer Regulator
R-1*	Inner Container Bursting Disc
R-2	Vacuum Evacuation Port/Outer Vessel Relief Device
RV-1	Relief Valve
V-1	Liquid Fill/Withdrawal Valve (Blue hand wheel)
V-2	Full Trycock & Vent Valve (Grey hand wheel)
V-3	Gas Withdrawal (Use) Valve
V-4	Pressure Builder Valve (Green hand wheel)
VC-1	Vaporizer Coil

*NOTE: R-1 to be replaced with Relief Valve set at 36 bar when the cylinder is used for Liquid CO₂ Service.

❖ **Liquid Fill/Withdrawal Valve (V-1)**

Liquid product is filled into or withdrawn from the container through the connection controlled by this valve. It is equipped with a connection specifically required for the liquid service, for which the container is configured. If the liquid service changes, this connection must be changed as well. The valve is opened for liquid fill or liquid withdrawal after connecting a transfer hose with compatible fittings to the liquid line connection.

❖ **Full Trycock & Vent Valve (V-2)**

This valve controls a line into the head space of the container. It is used during the fill process. The vent valve acts as fill point during the pump transfer or to vent the head space area while liquid is filling the inner container during a pressure transfer fill through the LIQUID valve. The vent line serves as full try cock at 95% of the inner container fill volume.

❖ **Gas Withdrawal (Use) Valve (V-3)**

This valve (also called USE Valve) controls the withdrawal of gas produced by the internal product vaporizer (VC-1). The withdrawal line is equipped with a connection specifically required for the gas service, for which the tank is configured. If the gas service changes, the connection must be exchanged.

❖ **Pressure Gauge (PI-1)**

The pressure gauge displays the internal container pressure in bar or in psi.

❖ **Liquid Level Indicator (LI-1)**

The container liquid level indicator (LI-1) is a float type liquid level sensor that indicates container liquid content through a magnetic coupling to a yellow indicator. This gauge is an indication of approximate container contents only and should not be used for filling; liquid cylinder should be filled by weight. If the level indicator does not move when container is filled, it may indicate that the magnetic field between the level indicator and the gauge has been uncoupled. The indicator should recouple itself as the container is empty.

❖ **Inner Container Relief Devices**

These cylinders have inner container relief valve (RV-1) and inner container burst disc (R-1) with setting as below:-

Description	XL™-M (LC-M)	XL™-H (LC-H)
Relief valve	16 bars	24 bars
Burst head	25 bars	36 bars

❖ **Pressure Building and Economizer (PCV-1)**

The combined pressure regulator (PCV-1) controls the withdrawal of gas from the gas space to reduce the pressure in the tank, if it is higher than the set pressure. The pressure reduction avoids the loss of product by blowing safety valves, if the withdrawal from the tank is low. If the pressure in the tank is below the set pressure,

the regulator activates the pressure building system. If P/B valve (V-4) is open, the pressure regulation operates automatically at the set pressure without any further care.

❖ **Vaporizer Coil (VC-1)**

These XL™ (LC)-cylinders are equipped with an internal product vaporizer coil (VC-1), fixed on the inner side of the outer casing to serve as a heat exchanger with the ambient temperature. The product vaporizer heats up and evaporates the liquid product for the withdrawal of gaseous product. The capacity for the gas withdrawal is up to 9.2 m³/h (nitrogen). If vaporizers are activated, a build-up of ice in the coil area on the surface of the outer vessel is normal and unavoidable. An additional external vaporizer should be connected, if the withdrawal is made at a continuously higher rate in order to ensure the full evaporation of the withdrawn product and to warm it up to avoid frost damages on connected equipment, hoses and components.

7. Pressure Building

The XL™ (LC) Series are equipped with a pressure building circuit (PBC-1) in addition to the internal product vaporizer (VC-1).

A pressure building circuit is used to ensure sufficient driving pressure during high withdrawal periods. The function is actuated by opening the PB valve (V-4) that creates a flow from the bottom of the container, through the pressure building coil, the regulator into the gas space in the top. When the pressure valve is open, and the container pressure is below the set pressure of the regulator, liquid taken from the bottom of the container is warmed up and vaporized in the pressure building coil as heat exchanger which is inside the outer casing. The expanding gas is fed into the upper section of the container to build up pressure.

Pressure Building is not often required unless container pressure drops below the gas output pressure desired. But it allows a sufficient pressure in the tank, even if up to 9 m³ per hour are continuously withdrawn. For many applications, where the container pressure is raising due to low withdrawal rates, it may make sense, to deactivate the pressure building circuit by closing PB valve (V-4).

8. Withdrawal Gas from the Container

To withdraw gas from the XL™ (LC)-containers connect a suitable pressure regulator to the gas withdrawal connection (CN-3), and the output of the regulator to your external equipment. The gas is withdrawn over the internal product vaporizer coil (VC-1). Then open the gas withdrawal (use) valve (V-3), and if the pressure is low, open the pressure builder valve (V-4).

When the pressure in the XL™ (LC)-container is high enough, set the pressure on your pressure regulator.

Caution: *During high gas withdrawal rates above 9.2 m³ / hour the capacity of the internal vaporizer may be exceeded. If the capacity of a vaporizer is exceeded, the withdrawn gas may become very cold, or even contain liquid gas. This can heavily damage the connected equipment, hoses, and components. An additional external vaporizer should be connected, if the withdrawal is made at a continuously higher rate in order to ensure the full evaporation of the withdrawn product and to warm it up to avoid frost damage.*

9. Withdrawal Liquid from the Container

To use the container in liquid delivery service, attach a transfer hose to the liquid fill/withdrawal connection (CN-1) and open the adjacent liquid/fill withdrawal valve (V-1). The pressure in the container will drive liquid product out through the valve if the container pressure exceeds that of the receiver.

The rate of liquid withdrawal from these containers is variable depending on the container pressure and the saturation temperature of the liquid.

Caution: *As a rule, always close the valve before you disconnect the hose when the container is empty, in order to avoid contamination.*

10. Filling the Container

Visually inspect the container. Do not attempt to fill container that have broken or missing components. Filling procedures must always ensure there is enough gas head space left on the full container for liquid to expand as it warms.

There is a difference between filling a 'cold' or a 'warm' container. A container is called 'warm' if it was longer than 24 hours without filling. A 'cold' container should contain a residual of liquefied product gas.

Taylor-Wharton offers metal hoses for filling and withdrawal as accessories.

WARNING: Filling operations should take place only in well-ventilated areas. Accumulations of product gas can be very dangerous (refer to the safety precautions in the front of these instructions). Maintain adequate ventilation at all times.

a) **Filling Container by Full Trycock (refer Flow Diagram)**

Filling the container this way employs the full trycock & vent valve (V-2) as full trycock at 95% of the useable volume.

(i) **Filling Cold Container**

- (1) Connect a transfer hose to the source tank and cool down the hose by slowly opening the tank valve letting the cold gas flow out to the atmosphere.
- (2) Then connect the transfer hose to the fitting of the liquid fill/withdrawal valve (V-1) of the container.
- (3) Open the trycock & vent valve (V-2) and the liquid fill/withdrawal valve (V-1) on the LC container, and finally the valve on the source tank.
- (4) Observe the liquid level indicator (LI-1) and the open trycock & vent valve (V-2) on the XLTM (LC) container. The container is full if liquid is blowing out of this valve. The valve on the source tank must be closed immediately.
- (5) Carefully disconnect the transfer hose. Because it may be under pressure and because of the thermal expansion of the liquid in the hose, unscrew the connections very carefully and slowly and remove the hose.

Caution: To avoid contamination, close the liquid fill/withdrawal valve (V-1) before disconnecting the transfer hose.

- (6) Close liquid fill/withdrawal valve (V-1) and trycock & vent valve (V-2).
- (7) Check trycock & vent valve (V-2) for eventual over filling, let out liquid gas before finally closing it. The filling procedure is ready.

(ii) Filling Warm Container

A warm container should be filled slowly, interrupted with breaks. So that it can be ensured, that the pressure in the container is not increasing too much. Otherwise use the same procedure as above.

b) Filling Container by Weight (refer Flow Diagram)

Using the procedure below, first determine the proper filled weight of each container (refer to filling weight table). The weight derived is then used in the filling procedure that follows:

- (1) Move the container to filling station scale and weight it both with and without the fill hose attached to determine the weight of the fill line assembly. The difference is the fill line weight.
- (2) To determine the weight at which the fill should be stopped, add the desired fill weight from filling weight table), the transfer line weight and the tare weight from the container's data plate.
- (3) Once you have determined the proper full weight for a container, connect a transfer hose to the low-pressure source of liquid.
- (4) Open the supply valve from storage tank. Then on the XL™ (LC) container open the liquid fill/withdrawal valve (V-1) and vent valve (V-2) to begin the fill.
- (5) Observe the container pressure and control the pressure of 0.7 to 1 bar by throttling the vent valve (V-2).
- (6) When full weight is reached, close both liquid fill/withdrawal (V-1) and vent (V-2) valves. Close the liquid supply valve from source liquid.
- (7) Carefully disconnect the transfer hose. Because it may be under pressure and because of the thermal expansion of the liquid in the hose, unscrew the connections very carefully and then slowly remove the hose.
- (8) Remove the container from the scale.

Note: The weight calculation must consider the residual liquid in the container that is to be filled. The fill weight shown below are for liquid saturated at atmospheric pressure. The actual fill weight for your application depends on the saturation temperature of liquid in your storage tank and may be determined by weighing.

Determine Proper Full Weight

To determine the full weight at which the fill should be stopped, add the desired fill weight from the filling weights table, the transfer line weight, and the tare weight from the container's data plate.

Filling Weights Table

Fluid \ Model	LC180M	LC193M	LC176H	LC208H	LC247H
Nitrogen	124 kg	133 kg	114 kg	135 kg	160 kg
Oxygen	176 kg	189 kg	163 kg	208 kg	229 kg
Argon	214 kg	229 kg	199 kg	235 kg	279 kg
Carbon Dioxide	-	-	176 kg	208 kg	234 kg

11. Repair and Maintenance

Read the Safety Precautions in the front of this manual before attempting any repairs or maintenance on these containers. Also, follow these additional safety guidelines while performing container maintenance:

- **Never work on a pressurized container.** Open the vent valve (V-2) as a standard practice during maintenance to guard against pressure build-up from residual liquid.
- Containers that are in service for oxygen may contain residual oxygen. Many materials and working practices together with oxygen can be a combustion hazard. For that reason, an oxygen container must be sufficiently emptied and rinsed with nitrogen for instance, to remove the oxygen from the container before repair and maintenance work can start.
- **Use only repair parts suitable for oxygen service. This basic rule is as well valid for containers, which are at that time not in oxygen service, because they may be in the future.** Be certain your tools are free of oil and grease. This is a good maintenance practice and helps ensure you do not introduce any contaminants to the plumbing of the container.
- **Leak test connections after every repair.** Pressurize the container with an appropriate inert gas for leak testing. Use only leak test solutions approved by Taylor-Wharton.

12. Change of Gas Service

The XL™-MP (LC-M) series containers are designed for Oxygen, Nitrogen, and Argon; the XL™-HP (LC-H) series models as well for CO₂. They can be converted from one service to another within the confines of the services for which the containers are designed if a change of the gas service should be desired. For this conversion, the connection fittings on the pipes must be exchanged, further the scale on the liquid level gauge.

Warning: *We must advise against changing the service of a container to any other gas, once it has been in service for carbon dioxide, because carbon dioxide may have caused a contamination with hydrocarbons, which is a combustion hazard with oxygen. This hazard must also be considered for an eventual change from carbon dioxide to nitrogen or argon service, because the service may later be changed again to oxygen.*

Container Modification

Empty the container and open the vent valve to allow residual liquid to evaporate and to prevent the container from building up pressure.

Caution: *Always change the fittings, never use adapters if the service shall be changed.*

- (1) Unscrew the fittings of the connections to the vent (gas blow) line, and the liquid (fill/ withdrawal) line –one after the other-. Screw in the new fittings for the desired medium service. Seal with Teflon/ PTFE band or similar, but make sure that the sealing material is clearly declared for oxygen service.
- (2) Exchange the snap on Indicator on the liquid level gauge against the indicator for the new medium.
- (3) Carry out a leak test on all fittings that have been exchanged. Change the stickers or decals on the container about gas service and possible handling instructions.

13. Purge Procedure

After changing the cylinder gas service, determine the level of purity in the pressure vessel. If the pressure vessel contents purity is unacceptable, perform a purge procedure to reduce contaminants. The following procedure is recommended for the applications:

- (1) Attach warm nitrogen, N₂, source to the liquid fill/withdrawal valve, V-1. Approximately 20 psig pressure should be achieved. The positive pressure must

always be maintained in the cylinder during purge procedure to prevent drawing atmospheric contaminants back into the cylinder.

- (2) Closed all valves. Before venting to atmosphere ensure that such venting is allowed by all applicable site regulations and codes.
- (3) Open vent valve, V-2. Vent the inner vessel to 5 psig (34kPa). Close vent valve, V-2.
- (4) At this low pressure 5 psig (0.35 bar), loosen the compression fitting connection on the pressure build regulator, PCV-1 so that N2 vented thru this connection. Then retighten the connection while the cylinder is still having positive pressure.
- (5) Repeat purge procedure 1 through 3 until an acceptable product purity is achieved.
- (6) After completion of cylinder purge, make sure that all valves are closed.

14. The Dual Stage Regulator

A dual stage, spring loaded regulator is employed for the pressure building/ economizer circuit. This regulator can be adjusted on the container, or it can be replaced. It is also possible to check and adjust the regulator off the container in a readily fabricated bench adjustment fixture.

Please note: One clockwise turn of the adjustment screw will raise the set point by approximately 2 bars. Do not attempt to set the regulator to a pressure outside of its design range.

Design ranges:

- Medium Pressure- 16 bar containers: 5 to 12 bar, standard set point: 8 to 9 bars
- High Pressure- 24 bar containers: 11 to 25 bar, standard set point: 21 to 22 bars

The offset between pressure building and economizer is about 1.4 bars.

15. Regulator Adjustment on Container

- (1) Fill the container to approximately 2/3rd with liquid product.
- (2) Open the pressure builder valve (V-4) and allow the container to stabilize, until the pressure does not change any more during half an hour. Note the point, when the pressure stabilizes, this is the set pressure of the dual pressure building/economizer regulator (PCV-1).

- (3) Increase the set pressure by clockwise turning the adjustment screw on the regulator. Watch the pressure in the container to increase until it stabilizes. If you want to lower the set pressure, turn it anticlockwise, then close the pressure builder valve (V-4), and vent the container to a pressure below the desired set pressure. Repeat step 2 in order to observe the change.

16. Checking Container Performance

The XL™ (LC) containers consist of two containers, one inside the other. The space between the containers acts as a highly efficient thermal barrier including high technology insulation, a vacuum, and a vacuum maintenance system. Each serves a very important part in the useful life of the container. The high technology insulation is very effective in preventing radiated reaching the inner container. Unfortunately, the perfect vacuum cannot be achieved since trace gas molecules begin to enter the vacuum space from the moment of manufacture. The vacuum maintenance system consists of materials which gather trace gas molecules from the vacuum space. The maintenance system can perform its function for years, but it has a limited capacity. When the vacuum maintenance system is saturated, it can no longer maintain the vacuum integrity of the container. The change will be very gradual and may go unnoticed for several years. When the vacuum in the insulation space is no longer effective, the following symptoms may appear:

- (1) With liquid in the container and pressure building coil not in use, the outer casing will be much colder than comparative containers.
- (2) Frost, indicating the liquid level, may be visible on the outer casing of the container.
- (3) The container may appear to 'sweat' if the air surrounding the container is hot and humid.
- (4) The relief valve will open continuously until the container is empty.
- (5) The container will hold pressure for several days but will not hold liquid.

Similar symptoms can be observed if the pressure building is activated or damaged. Pressure builder valve (V-4) and / or pressure build regulator (PCV-1) may be defective or need to be re-adjusted / replaced. It can be observed by an iced or very cold regulator, valve, and pipes from a damaged vacuum.

17. Checking Normal Evaporation Rate (NER- Test)

If you have reason to suspect a loss of the vacuum integrity, you can check the container's Normal Evaporation Rate. Before you start testing, check first the integrity of the Vacuum Evacuation Port/ Outer Vessel Relief Device (R-2). If the Vacuum

Evacuation Port/ Outer Vessel Relief Device (R-2) is defective, there is no more need for the test. In that case the container would need to be re-evacuated after the reason for the vacuum loss was found. In case there is a vacuum leak, for instance by a crack in the outer or inner casing, on the neck tube, or on one of the pipes, a repair would make no more sense for economical reasons. Please contact your dealer.

If the Vacuum Evacuation Port/ Outer Vessel Relief Device (R-2) is ok, carry out the NER- Test. The test measures the actual product loss over time.

Please note: *The Pressure Builder Valve (V-4) must remain closed during the test; otherwise, the pressure building process would increase the evaporation and distort the test result. It must be ensured, that the Pressure Builder Valve (V-4) closes 100%.*

- (1) Fill the container with about 68 kg of liquid nitrogen.
- (2) Close the liquid fill/withdrawal valve (V-1) and open the vent valve (V-2) and allow it to remain open during test.
- (3) The liquid nitrogen boils because it is pressurized. After 24 hours the saturation process should be finished, so that the evaporation from the container is stabilized. Then weight it, and record the weight, time, and date.
- (4) Repeat the weighting after 24 hours and again after 24 hours.
- (5) The results will be most reliable if the container is not moved during this time. The resulting weight loss over 24 hours is the daily evaporation rate. You can of course as well measure weight and time on any times of the day to find the hourly evaporation and to calculate the daily evaporation rate. The measured values must be a linear function of time.

Compare the results of your test to the 'as manufactured' NER value in the specification sections of this manual. A container in service should maintain an NER value of less than two times the new specification. Any test result greater than two times the listed value is indicative of a failed or failing vacuum. If NER is found to be high, contact Taylor-Wharton or your distributor.

An increased evaporation rate is shown by a fast pressure building, but it is not dangerous, because the container is protected by a safety valve and a burst disc. There are no objections against a further operation of the container, if there is a continuous and enough withdrawal, at least until a blowing safety valve shows, that the evaporation rate of the container is too high and the vacuum to deteriorate for the present application.

18. Liquid Content Gauge

This device consists of the gauge assembly with a float rod beneath an indicator under a clear plastic protective cover. When the gauge is assembled, a level indicator ring is magnetically coupled to the top of a float rod and moves up or down with the changing liquid level in the container.

If the indicator ring stays in the bottom position, although there is still liquid in the container, this can be a sign for an interrupted magnetic coupling between the ring and the float rod. The indicator ring will be picked up again by the magnetic field once the container is empty. You can also try to lift the ring in its position with a magnet from outside.

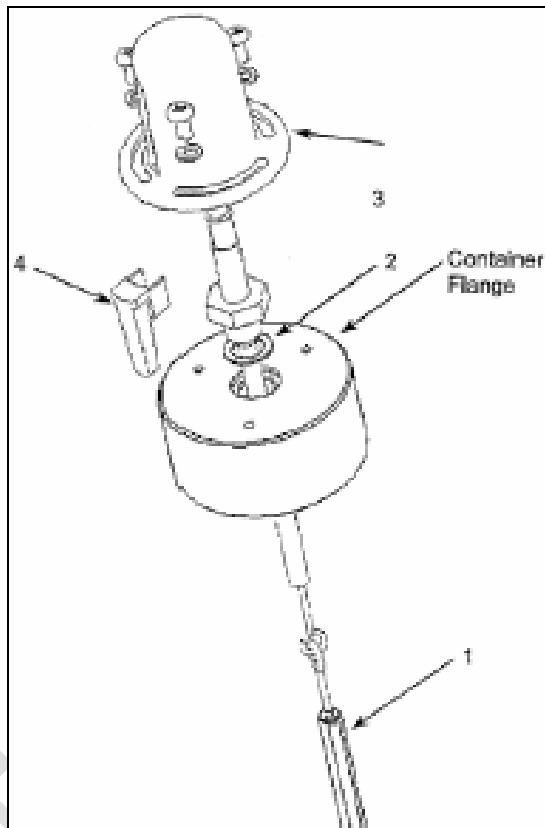

Components of the Contents Gauge:

- 1 - Float rod
- 2 - Sealing
- 3 - Cover
- 4 - Scale (Clip)

19. Replacement Instruction

Caution: Please refer to section “Repair and Maintenance” before doing the following replacement.

Liquid Level Indicator Replacement

a) Removing the Full View Contents Gauge

- (1) Vent all pressure from container.
- (2) Remove the protective cover by removing three bolts from the base of the cover.
- (3) Unscrew the gauge body using a wrench on hex fitting at base of the indicator.
- (4) Lift the entire gauge assembly free of the container. The gauge assembly is long and may be very cold. Gloves should be used to protect your skin.

WARNING: Cold surfaces should never be handled with bare skin. Use gloves and other protective clothing when performing this procedure.

b) Liquid Level Indicator Installation

Before installing a new liquid level indicator or repaired, inspect the gasket seals. If any damage is apparent, replace the gasket.

- (1) When inserting the gauge assembly, lower the float rod through the gauge opening until about 8 inches (203 mm) of the float rod remains above the container.
- (2) Grasp the clear cover portion of the gauge assembly with two fingers so that the assembly hangs free and “plumb.”
- (3) Lower the assembly about 4 inches (102 mm) slowly and try to keep the rod in the center of the threaded entrance hole as you do. If you are careful during this portion of insertion, you will drop the float rod straight through the guide ring inside the cylinder.

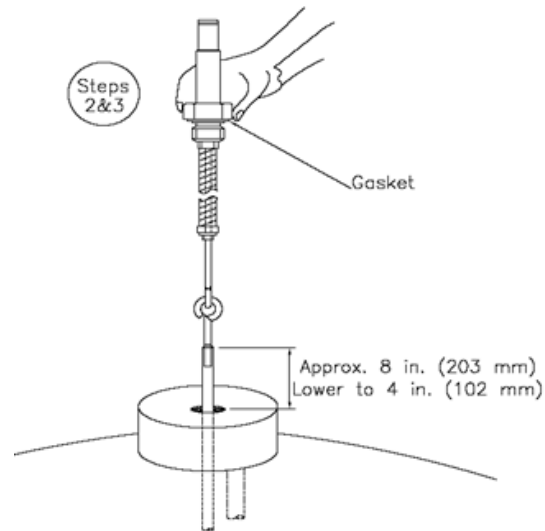

- (4) To confirm that the rod is correctly positioned in the cylinder, stop where you can still grasp the top of the rod and try to swing the lower end from side to side.

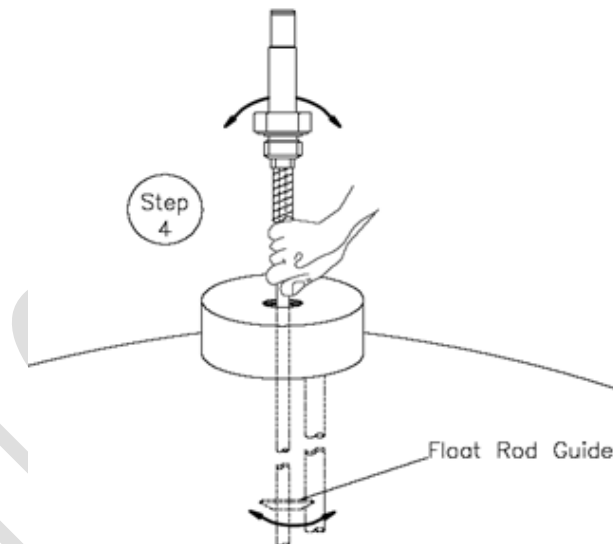

- (5) When the rod is engaged in the guide ring, the rod will be restricted to lower end movement of about 1/2" inches (12.7 mm); if you can feel greater movement, withdraw the rod to the point where its top is 8 inches (203 mm) above the gauge opening and try again.
- (6) When you are satisfied that the float rod is correctly installed, lower the assembly the rest of the way into the container until the top portion threads can be engaged.

- (7) Screw the gauge in place and hand torque to about 20 lbs-ft (2.8 kgf-m).
Leak check the connection of gauge to the flange.

CAUTION:

When installing the gauge assembly, care must be taken to ensure that the float rod is inserted through “guide ring” located on the liquid withdrawal line inside the container. If the gauge does not engage this ring, the contents indication will be inaccurate, or the gauge may be damaged in use.

Hand Valve Replacement

Hand valves are an integral part of the container, and the valve bodies rarely need replacement. However, the handwheel and internal parts of the valves are renewable. The illustration below is a view of the valve replaceable part used on Taylor-Wharton liquid container.

Valve Repair Kit Assembly

➔ 3/8” Rego Globe

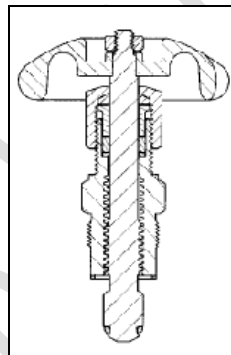
a) Valve Disassembly Instructions

- (1) Open valve by turning Handwheel counterclockwise as far as it will go to release any trapped gas in the system.
- (2) Using a large adjustable wrench to hold valve body, remove Bonnet by turning counterclockwise with a 15/16-inches socket wrench that capable of developing at least 80 lbs-ft (11 kgf-m) torque.
- (3) Remove the handwheel assembly from the valve body and discard. Inspect body and clean if necessary; be sure interior and seal areas are free from dirt, residue, and foreign particles.

CAUTION:

***Do not apply force after valve is fully open.
Do not scratch or mark internal surface of valve.***

b) Valve Replacement Instructions

- (1) Thread handwheel assembly into valve body until properly seated.
- (2) Turn handwheel completely clockwise to close valve. Re-pressurize container and leak check valve.

Relief Valve / Inner Container Bursting Disc / Pressure Gauge Replacement

Unscrew the part to be removed by suitable socket wrench. Apply approved sealing tape to the thread of new parts to be installed. Using a suitable socket wrench, screw back the parts to its connection. Leak test connection after replacement (refer to section “Repair and Maintenance”).

Foot Ring Parts Replacement

COMPONENT FOR SHOCK MOUNT FOOT RING

Item No.	Description	Part No.	Qty.
1	Rubber Shock Ring	XL50-4C18	1
2	Foot Ring	XL50-4C19	1
3	Hex Nut	6310-0135	3
4	Washer	6430-0125	3
5	Carriage Bolt	6620-0401	3

Shock Mount Foot Ring- Exploded View

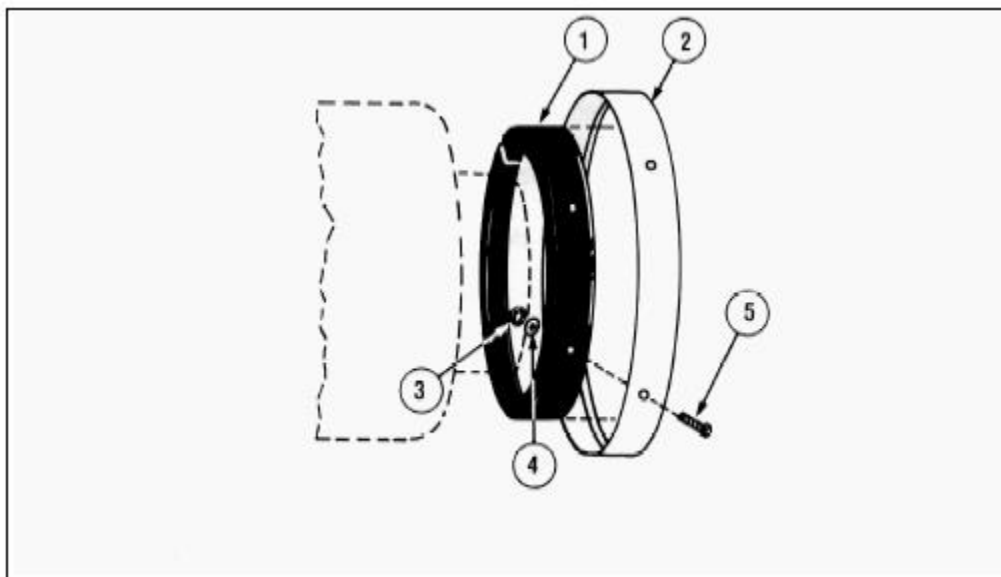

Square Base Parts Replacement

COMPONENT FOR SQUARE BASED ASSEMBLY

Item No.	Description	Part No.
1	Cap screw, Hex Head, ½”-13UNC, S.S.	6164-1753
2	Hex Nut, Nylon Insert	6331-1183
3	Handle Assembly	XL65-9C31
4	Flat Washer, S.S.	6460-9024
5	Spring Washer, S.S.	6460-9025
6	Flat Washer, Teflon	6160-9026
7	Caster, Swivel 4 in. Dia. Wheel	7300-9021
8	Caster, Rigid 4 in. Dia. Wheel	7300-9022
9	Carriage Bolt, 3/8”-16UNC, 1 ¼” L, S.S.	6160-4766
10	Hex Head Cap screw, 3/8”-16UNC, 1” L, S.S	6164-1133
11	Elastic Stop Nut, S.S.	6368-9110

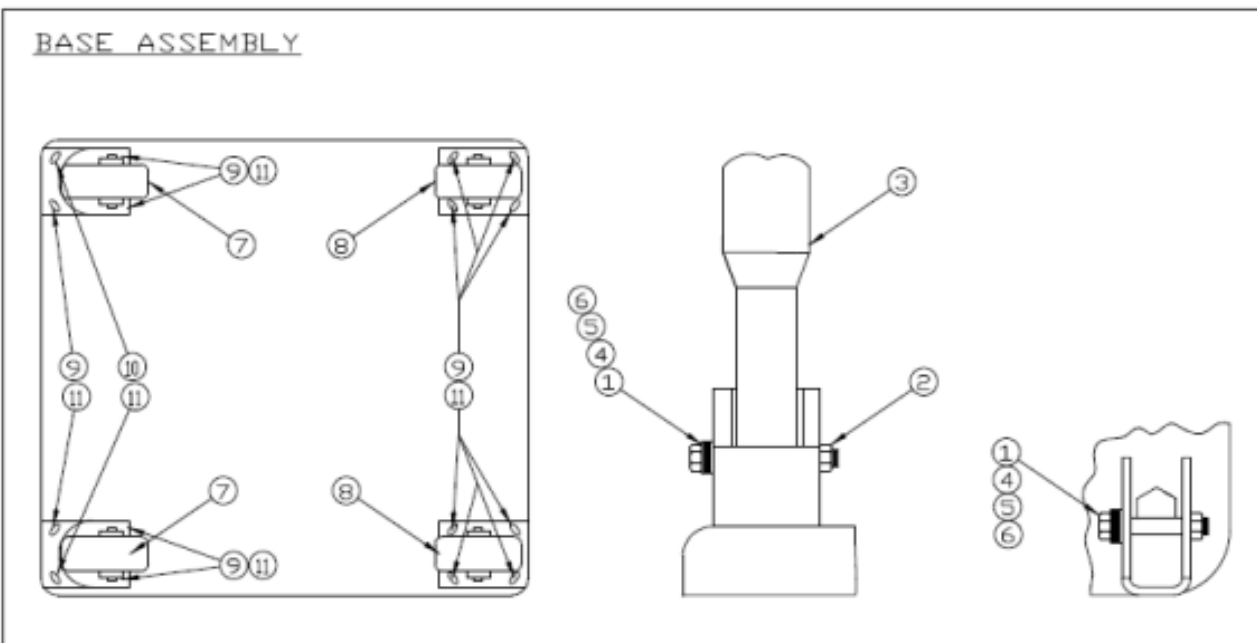

Round Base Parts Replacement

COMPONENT FOR ROUND BASE ASSEMBLY

Item No.	Description	Part No.	Qty
1	Caster wheel, 125mm Dia., Nylon	7300-9033	3
2	Caster wheel with brake, 125mm Dia., Nylon.	7300-9034	2

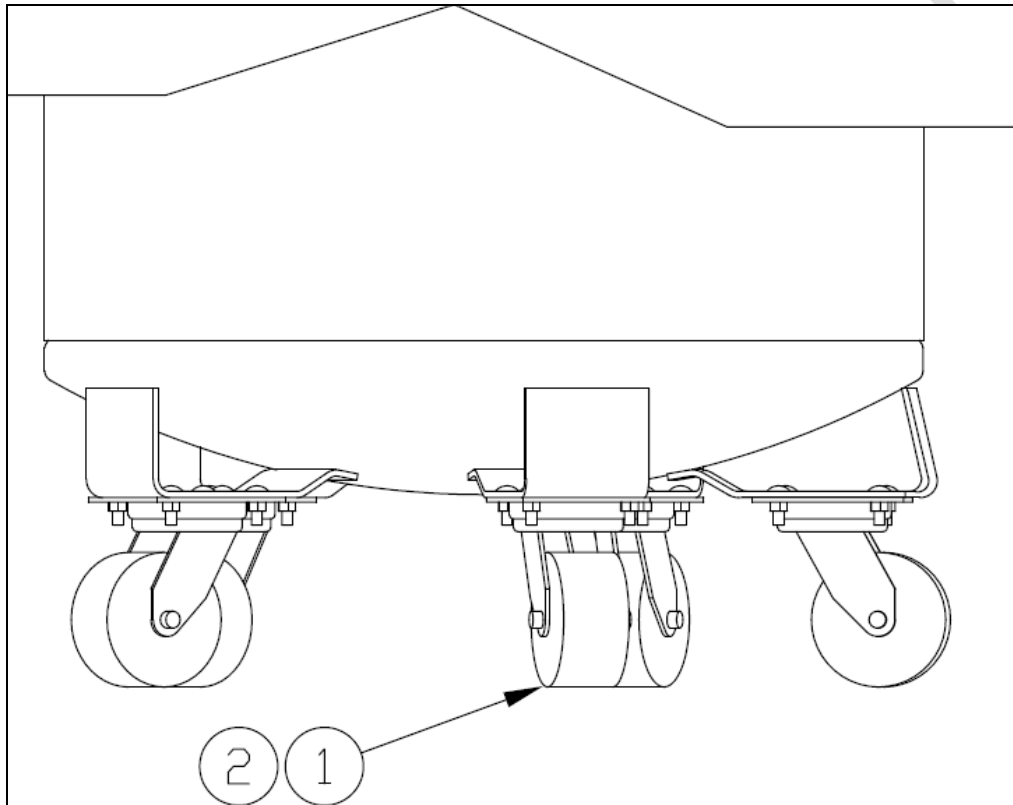

16. Trouble Shooting Chart

No	Symptom	Possible Cause	Corrective Action
1.	Operation pressure always too low	<p>(1) Safety valves open at low pressure.</p> <p>(2) Burst disk of the inner vessel broken, or safety valve does not close properly.</p> <p>(3) Leaking pipe, valve, or others component.</p> <p>(4) Very cold, fresh liquid</p> <p>(5) Regulator is closed or doesn't open properly.</p> <p>(6) Pressure builder valve closed</p>	<p>(1) Replace safety valve.</p> <p>(2) Replace burst disk and check the safety valve.</p> <p>(3) Carry out leak tests and repair detected leaks.</p> <p>(4) Container will build pressure over time, or an external pressure source can be used to pressure container. IF the container with PB circuit, open pressure building valve.</p> <p>(5) Replace regulator.</p> <p>(6) Open pressure builder valve. If the pressure builder valve is closed, the pressure in the container increases very slowly only.</p>
2.	Pressure indicator on a full container displays no or a too low pressure.	<p>(1) Pressure indicator damaged.</p> <p>(2) Leaks in valve or plumbing.</p> <p>(3) Open inner container safety head.</p> <p>(4) Liquid too cold.</p> <p>(5) Faulty safety valve.</p>	<p>(1) Replace damaged pressure indicator.</p> <p>(2) Leak test and repair leaks. For valve repair, see hand valve repair section.</p> <p>(3) Replace the damaged safety head.</p> <p>(4) Allow container to stand and build pressure.</p> <p>(5) Replace safety valve.</p>
3.	Container is very cold outside, it is sweating, perhaps it's partly iced outside, to the high of the liquid level. It cannot keep the liquid over night; the safety valve is	Vacuum lost, check outer vessel's burst disk if broken.	Contact your Taylor-Wharton Or your dealer for further advice. Do not fill the vessel again with liquid.

	blowing gas.		
4.	Lower part of the container iced.	Pressure building system is working. If the pressure in the container is higher than the set pressure of the regulator, the regulator or the pressure build valve does not close properly	Close or replace the pressure builder valve, check set point of the regulator, if damaged, replace or repair it.
5.	Relief valve releases gas during the operation of the container (at maximum working pressure), although the vacuum is ok.	(1) Set pressure of the regulator is too high (higher or close to relief valve set pressure) (2) Withdrawal rate is to low	(1) Correction of regulator set pressure, eventually close pressure builder valve. (2) Product loss cannot be avoided, perhaps a manual venting is a preferred measure.
6.	Container lost gas for a certain while after it has been filled up.	Normal procedure. Happens because of evaporation during cooling of the container and boiling of the liquid until the saturation process is over.	No special action required. The symptom is over when the liquid temperature boiled down to the saturation temperature.
7.	Relief valve is continuously blowing.	Evaporation losses are too big.	Check the functions of the vessel (see corresponding chapter of this manual), to find out, if the vacuum performance is still ok.
8.	Liquid level indicator is always on full, without movement.	Float rod is blocked within the guidance ring.	Move the container to unblock
9.	Liquid level indicator is always on empty, although the container is full or partly filled.	Magnetic coupling between the ring and the float rod interrupted can happen if container was put down a little too heavy.	Catch the ring with a magnet from outside and lift it up, until it catches the magnetic field of the float rod.

Disclaimer

Taylor-Wharton is not being liable for any consequential, special, or incidental damages or accidents resulting from the delivery, use, or maintenance of delivered XL™ (LC)-containers (including loss of any liquid product or materials stored in liquid product), or from any cause whatsoever by accepting delivery of the products sold hereunder. Any claims on the containers must be reported immediately in written form to TW after receipt of the XL™ (LC)-container, or whenever a damaged becomes obvious. The XL™ (LC)-container may not be put or kept in operation before clarification and repair of the damages, and it must be put out of any service and stored in a suitable form. The LC-container may be put in service again only after written consent of TW.

Furthermore, the 'Terms of Sales or Acknowledgement' of Taylor-Wharton apply.



Taylor-Wharton
Since 1742

TAYLOR- WHARTON MALAYSIA SDN. BHD

Lot Nos. PT5073, 5076 & 5077
Jalan Jangur 28/43
Hicom Industrial Estate
40400 Shah Alam
Selangor Darul Ehsan, Malaysia
Fax: 00 603 5191 1472